



azar **nasim**  
AIR CONDITIONING COMPANY

---

## AIR HANDLING UNIT



## Features

---

In all Azar Nasim air handling units the frames are from aluminum profiles while the chassis and body panels are made from galvanized steel sheets in appropriate thicknesses.

azar nasim air handling units are manufactured in sections descriptions of which are offered below. All units are completely painted in the proper thickness.

Azar Nasim has a wide range of air handling units for use in various applications from small office premises to larger industrial applications. Common to all items in the range is that systems and components have been to satisfy stringent demands for low energy consumption. Heat exchangers, motors and fan units have all undergone extensive testing, both in the laboratory and out in the field, in order to comply with current and future demands for low energy consumption. All products are also manufactured to comply with environmental requirements. To ensure easy installation, many of these units feature control systems enabled for plug-and-play, i.e. simple start-up. Azar Nasim air handling units are manufactured in sections descriptions of which are described below. Heat exchangers, motors and fan units have all undergone extensive testing, both in the laboratory and out in the field, in order to comply with current and future demands for low energy consumption. All products are also manufactured to comply with environmental requirements. To ensure easy installation, many of these units feature control systems enabled for plug-and-play, i.e. simple start-up. Azar Nasim air handling units are manufactured in sections descriptions of which are described below.

### ❖ Frame

- Low weight, corrosion resistant, marine aluminum alloy twin box section profile, is designed to provide strength and stability
- Polyamide gaskets between the frameworks panels and profiles, to allow efficient cleaning and prevent trapping and harmful bacteria growth
- Optional thermal bridge free profile For each component of the system a specific frame is made by Azar Nasim Company which will be discuss in the related sections.

## ❖ Panels

Panels used in Azar Nasim air handling units consist of an interior sheet, an exterior sheet, and insulating material. The insulating material is placed in pieces between the interior and exterior sheets.

Since interior and exterior sheet thicknesses used for panels are much less than the thickness of the insulating, sheet thickness does not have much effect on the thermal conductivity coefficient of the panel. The dimensions and material used in Azar Nasim AHU is described below.

- Standard 20mm or 50 mm thick (other thickness optional) double skinned galvanized panels
- 0.75mm internal and 1.5mm external skins with 50kg/m<sup>3</sup> to 70kg/m<sup>3</sup> density glass wool, rock wool or k-Flex insulation.
- Returned "K" value of 0.036W/m<sup>2</sup>K
- Optional panels manufacturing from pre-plastic coated steel, pre-painted metal or stainless steel
- Different thick panels available upon request.

## ❖ Fans

The air handling unit includes a fan cell for the purpose of facilitating air circulation through an aspirator and/or ventilator, depending on the requirements of the environment. While forward curved fans are preferred for units within the low pressure range, forward curved or reverse curved fans can both be used for units within the medium and high pressure ranges. In addition to these, Aero-foil fans are commonly preferred due to their efficiency and low noise level operation. Depending on design conditions Plug (without scroll case, single inlet, direct coupled) fans can also be used.

Fans and housing used in Azar Nasim air handling units are manufactured from galvanized sheet metal. One or two double inlet, double width forward or backward curved centrifugal fans are used in Azar Nasim air handling units. Aerodynamic Inlets design, with static and dynamic balancing of the wheels according to airflow and speed is the main purpose. Fans and pulley are connected by a key to the shafts and designed for continuous operation at maximum rated fan power and speed.

Shafts and other power transmission components such as pulleys and belts are also suitably chosen depending on the required fan speed and electric motor power. The connection of the fan to another cell may be made by a diffuser. The basic purpose of the diffuser is to distribute the air flow in the subsequent cell evenly within the cell.

Fan, motor and drives are mounted on a fan and motor base that is isolated from the air handling unit by a set of anti-vibration isolators at the bottom in order to eliminate transfer of vibrations to the structure. To further reduce the effects of vibrations, fan outlet(s) are also connected to the structure via flexible material such as canvas. In cases where an air washer section is included, the blower electric motor is installed outside of this section to prevent adverse effects of moisture. In other cases, blower electric motor is installed in the fan section.

Electrical motors can be selected in the IP54, IP55, IP65 protection, and EFF1, EFF2 energy classes depending on place of use and on demand.

### ❖ Motor

Motors used in Azar Nasim air handling units are F isolation class, 380 V 50 Hz tri phase, enclosed, fan cooled and equipped with short circuit rotor as a standard. All 380V/30/50Hz electric motors are selected with insulation class of (F) and ingress protection of (IP-54). Electric motors with ingress protection of (IP-55) are also available upon request.

### ❖ 3 - Mixing box section

This section is where the fresh and return air streams are mixed in the mixing box. An independent air damper is included for each air stream.

Dampers are manufactured from aluminum in opposed blade configuration and air sealed through the use of rubber strip gasket . Damper actuators may be easily installed when required.

Washable aluminum filter modules 2 inches in thickness are arranged in (V) type configuration inside these boxes. A Housing for pleated type air filters may also be considered in the mixing box .

### ❖ Dampers

Dampers are equipment which allows flow rate adjustment by altering the air passage cross-section by its blades rotating on horizontal pins. These are used in air mixing and heat recovery units, for the purpose of handling the precise flow rate adjustment in an economical fashion.

Dampers are manufactured from aluminum in opposed blade configuration (to allow precise adjustment of the air flow rate) and air sealed through the use of rubber strip gasket. While setting dimensions of fresh air dampers in mixing chambers, the dimensions are determined to allow operation with 100% fresh air as required by the free-cooling system which can be used in transitional seasons. Damper openings can be controlled manually or by servo motor. Damper actuators may be easily installed when required, but the main issue which requires attention is to provide the air mixture rate needed for the system.

### ❖ Filters

One of the purposes of the air handling unit is to ensure the purity of the room air. Air filtering is related to the quantity, variety and size of the suspended impurities, the existence of contaminant gases or odors, and the desired filtering efficiency. For this reason, various filter classes with the ability to filter particles of various diameters have been developed. In Azar Nasim air handling units, various filtering options are applied and optimum options are offered depending on the place of use and upon requirements. Filter sections are designed for easy side withdrawal of the following filter types:

### ❖ Aluminum washable

High capacity, low resistance, permanent metal filters, which can be cleaned in hot water with detergent. They can be used for air cleanliness required 65-70% pollutants or as an economical alternate to disposable type pre - filter of high efficiency filter. Washable aluminum filter is made of a 5cm module in thickness encloses 5 flatted and corrugated aluminum sheets layers arranged in (V) type configuration.

Note: aluminum filters are installed in the mixing box section, not in the filter section.

### ❖ Panel Filters

Synthetic or glass-fiber media panel filters, class EU3 to EU5 (EU3 supplied as standard) arranged in galvanized steel frames. The decisive point in the design of these filters which have a gravimetric efficiency of 85-95%, is creating a corrugated structure and hence a larger filtering surface.

Its advantages with respect to flat filters are:

- Greater filtering surface
- Reduced front air velocity
- Greater efficiency
- Greater dust retention capacity
- Reduced front surface

Note: In cases where only pleated filters are required they are easily installed in the mixing box and not in the special filter section.

### ❖ Bag Filters

Synthetic or glass-fiber media bag filters, which allow a high filtering flow rate in relation to the front surface area, arranged in galvanized steel frames from class EU6 to EU9 (EU6 supplied as standard).

This equipment has the following advantages:

- Lower power requirement.
- Longer filter renewal interval.
- Lower energy costs.
- Lower maintenance.

### ❖ Hepa Filters

Require careful installation that guarantees complete air tightness of all gaskets. They are designed to eliminate virtually even the smallest particles in the air, i.e., those in continuous suspension (the smallest of these are only visible using electronic microscopes). Filters are available in 99.97 or 99.99 % efficiency with plywood or galvanized steel casing from class EU11 to EU14. Hepa filters are installed on specially designed knife edge type seal framing system with pressure tight lock to prevent air bypass They are specially recommended for:

- Hospitals
- Food industries
- Pharmaceutical companies
- Clean rooms
- Absolute filtering of air in environments with controlled contamination

They should be installed immediately before the space requiring this virtually sterile air that these filters can supply.

### ❖ Air HANDLING UNITS EQUIPPED WITH WATER-TO-AIR HEAT RECOVERY UNITS

Air Handling Units with water-to-air recovery units come with one copper tube/ aluminum wing coil to recover energy contained in the air released from the exhaust system on the equipment. A second coil is also installed at the fresh air section with the same characteristics. The aim of the second coil being installed is to transfer the energy obtained at the exhaust side into the fresh air.

### ❖ AIR HANDLING UNITS WITH PLATED TYPE HEAT RECOVERY

The philosophy for systems with plated air to air recovery units is slightly different. In this system, the energy transfer is made directly to fresh air from the exhaust air without any transferring liquid fluid (in reverse order for cooling conditions).

In the heat recovery units which are named as plated, aluminum plates are used which are shaped in a way to create different ways for the exhaust air and the fresh air. Fresh air and exhaust air meet on the unit in a way that they can never mix up and there occurs a heat exchange through the plates. In the practices where the air mixture is undesired, they are preferred with their high efficiency and they are the most common heat recovery units in this area. The fixed plated models are produced from aluminum material and they also facilitate inox and coating epoxy applications for different environments. Effective efficiency of those equipment can be up to 70% depending on the usage.

### ❖ AIR HANDLING UNITS WITH ROTARY TYPE HEAT RECOVERY

Rotary type heat recovery units are the most efficient heat recovery units in this area. The effective efficiency of the units varies from 50% to 85% depending on usage. Due to usage and installation, a slight unintentional mixture (2-5%) might occur. For the projects in which those mixtures are ignored, those units are preferred thanks to their high efficiency. In addition, with a proper Rotary type heat recovery units

are made of aluminum plates encircled one on the top of another. The plates are shaped in a way to allow airflow when they are one over the other. Units produced this way are installed into the air handling unit in a case. Those units make the epoxy application possible for hard conditions. They can also be produced in different types as Condensation and Enthalpy rotary to be suitable for the intended use.

### ❖ Humidification

The humidification unit is used to control the relative humidity of the ambient air by increasing the absolute humidity of air in the air handling unit. Water spray humidifiers are used in Azar Nasim air handling units in three different classes according to the application type.



## ❖ Air Washer

This is an air handling unit section which houses a series of water sprays which produce very small particles that come into contact with the circulating air flow and produce a high level of evaporation. The bottom of this section contains a drip pan, from which water is sent back to the sprays, with only evaporated water added back to the system. The water container manufactured from thick galvanized steel and protected by fiber reinforced polymer. The system requires the use of a water circulation motor pump, which is not normally included in the supply of this section. A price quote may be provided, however, upon request. The standard pump is supplied by electricity at 220 V / 3 phase/ 50 Hz. To prevent the entrainment of water particles, this type of humidifier is always equipped with a drip separator at the air outlet as a safety measure. Drop retainers are manufactured from polypropylene material or optionally from stainless steel material. Water spraying can be done either in the same or the opposite direction of air flow, resulting in different saturation efficiencies. The use of multiple units also increases efficiency, with the following experimental results obtained:

One unit only, same direction as air flow 60% efficiency:

- One unit only, opposite direction as air flow 75 % efficiency

Dual unit, same direction as air flow 84% efficiency:

- Dual unit, one in same and one in opposite direction 90% efficiency:
- Dual unit, opposite direction to air flow 95% efficiency

Azar Nasim air washers are designed & manufactured in three basic classes. Class 4: A compact & economical single spray bank air washer specially designed for effective humidifying & air washing purposes.

**Class 6:** A single spray bank unit for medium capacity applications is the ideal air washer for most types evaporative cooling & air washing tasks.

**Class 8:** A highly efficient heavy duty unit with two spray banks used whenever the utmost in heat transfer, humidification or air cleaning is required.

Basins are 300 mm deep for classes 4 & 6, 400 mm deep for class 8.

Moisture eliminators installed side by side in close proximity of each other preventing the water droplets from entering the fan section. They also present a large surface area against which water droplets & dust particles first impinge before ending up in the basin.

Centrifugal spray nozzles contain no cores, vanes or obstructions of any kind and all inside surfaces are smooth. Nozzles have removable caps which can be taken off for cleaning purposes. Brass flooding nozzles are installed on separate headers extending across the air washer. They deliver a solid flat stream of water on to the eliminator surface in order to wash off the dust particles & deposits. An access door with glass inspection window is available on all models. Make-up water connection & an automatic float valve which controls the water level in the basin are provided. Quick fill connection to which the fresh water supply may be connected is furnished for rapid filling of the basin.

### ❖ 5-Multi - Zone Section

In some cases the air conditioning design of a building defines different zones to be air conditioned, each zone requiring its own air flow rate and air temperature. In these cases instead of using a few air handling units, a multi-zone unit is usually chosen. In the multi-zone air handling unit, cooling and the heating coils are paralleled with each other which means that some of the air passes over the cooling coil and the remainder passes over the heating coil and at the outlet the result is a mixture of the two which has the suitable temperature for each zone. In multi-zone units the cooling coil area is the same size as that of a regular air handling unit while the size of the heating coil is less. For each zone two outlet dampers one which is on the cooling coil side and one that is on the heating coil side activate. Of these two outlet dampers as one opens the other one closes the same amount therefore, by adjusting the outlet dampers for each zone, the desired zone temperature is controlled. Number and the effective area of dampers for each zone are dependent on the number of zones and the air flow rate needed for that zone. These aluminum dampers are located either on top or the back side of this section depending on whether the type of air handling unit is up blast or horizontal blast discharge. Multi-zone section is usually installed after the fan section and in order to have the proper air flow over the coils an air diffuser is also installed. Humidifiers are also installed in this section when required.

### ❖ Hygienic Air Handling Units

The basic logic in its design is to form a structure which does not allow dirt accumulation, which is clean and whose cleanliness can be controlled. Air Handling Units comprise an extremely rigid sealed frame construction, therefore gaps between panel junctions are minimal, and consequently air leakage is greatly reduced. Profiles and corners forming the

skeleton have been manufactured from aluminum extruded profiles & polyamide corners internally round corner and edge eliminate microorganism growth at sharp edges and holes. In line with the requirements of hygienic air handling units, panels, profiles and sealing elements are manufactured from material which does not allow microbiological propagation and which can be chemically cleaned. An external aluminum profile maintains structural integrity and air-tightness without compromising the thermal-bridging characteristics of the unit and the special design eliminates the possibility of condensation, preventing contamination of the system. To protect the system from bacteria development and maximize Indoor Air Quality, two main conditions must occur:

1. Prevent the moist conditions that encourage bacterial and fungal development by using steam humidifiers rather than water spray systems.
2. Ensure that the Air Handling Unit is frequently cleaned.

### ❖ UV - C germicidal lamps

Air used in air handling units is cleaned with filtering systems. The coarse dust and particles in the air are captured with filters. Micro-organisms which are suspended in air and cannot be captured by regular filter systems, i.e. bacteria, viruses, moulds and funguses which threaten the health of humans, have their effect on personnel working in indoor spaces and on the product being manufactured. This leads to many financial losses.

Ultraviolet (UV) systems prevent all these microbiological problems. UV rays allow air sterilization. UV rays also neutralize bacteria which cause unwanted odors in the environment. UV air sterilization is a biological purification.

Areas of use: Hospitals (intensive care, operating room, corridors, waiting rooms), public health clinics, examination rooms, waiting halls, public offices and organizations, schools, hotels, plazas/offices, movie/theatre halls.

### ❖ Selection Procedure

The first parameter to consider in the selection of an air handling unit is the required air flowrate (CFM) therefore, by having the required air flow rate, coil face area and the available nominal air flow rate for the unit, the appropriate model may be chosen.

**Note :**

Allowable air velocity over cooling coil less than 550FPM. In air handling units equipped with air washers this allowable air velocity must be reduced further to less than 500 FPM.

Considering the cooling and heating loads and the entering air conditions. The number of coil rows, pressure drops on both water and air sides and the required model of fan may be determined using the data available in the catalogue. Other components and accessories such as air mixing box, special filters, humidifier, etc. May also be selected from the catalogue as needed.

**(Chilled Water Cooling, Hot Water Heating)**

Given:

Required air flow rate = 10000 CFM

Cooling entering air condition = 80 F°DB, 67 F WB Heating entering air condition = 60° F DB

Entering chilled water temp. = 45°F Leaving chilled water temp. = 55 F Entering hot water temp. = 180 F Leaving hot water temp. = 160 F Total cooling load = 480 MBH

Total heating load = 700 MBH Cooling & heating coil FPI = 14

External static pressure drop. = 0.78 In W. G Maximum coil face velocity = 500 FPM

Filter arrangement = V - type

Considering the required airflow rate in cfm and the uninominal airflow rate, model SRAH - 1000 is chosen. From table 2 @ the given cooling capacity and the chilled water temp. A 6 - Rows coil is chosen. (Cooling capacity of the unit is 498 MBH) From table 5 @ the given heating capacity and the hot water temp. A

2 - Rows coil is chosen. (Heating capacity of the unit is 726 MBH).

Note:

In cases where the requirement for number of fin per inch is not specified, a coil with the least number

of rows with either 8,10,12 or 14 FPI which satisfies the requirement is chosen. Preference is usually given to 14 FPI.

- Determine the actual coil face velocity.

$$\text{F.V. Actual} = \frac{\text{CFM}}{\text{F.A}} = \frac{10000}{20} = 500 \text{ FPM}$$

-Knowing the actual coil velocity and the coils chosen, determine the total internal air side pressure drop for the unit. From the table.

- P.D. Cooling coil = P. D. (Table 10) x C.F. (Table 10A) = 0.85 \* 1.45 = 1.19 In W.G
- P.D. Heating coil = P. D. (Table 10) x C.F. (Table 10A) = 0.22 \* 1.45 = 0.32 In W.G
- P.D. Filter = 0.099 In W.G
- P.D. Accessories = 0.05 + 0.06 = 0.11 In W.G (damper & mixing box from table 11).
- Total internal pressure drop (T. I.P .D)
- Total external pressure drop (T.E.P .D)
- T.I.P .D = P.D. Cooling coil + P.D. Heating coil + P.D. Filter + P.D. accessories
- T.I.P .D = 1.19 + 0.32 + 0.099 + 0.11 = 1.719 In W.G
- Total static pressure (T.S.P) = T.I.P .D + T.E.P .D = 1.719 + 0.78 = 2.5 In W.G

Therefore, by using table 18A and performing interpolation the required fan size is determined as 22" at the speed of 703 RPM and electric motor power requirement of 10 HP .

- Determine the water side P.D. (Cooling Coil):

- Water flow rate (GPM) =  $\frac{\text{Total Cooling load}}{500 \times \Delta T} = \frac{498000}{500 \times 10} = 99.6 \text{ GPM}$

- Water velocity inside the tubes =  $\frac{\text{Water Flow Rate (GPM)}}{\text{No. of coils} \times \text{No. of circuits (Table 19)}} = 1.235 =$   
 $\frac{99.6}{1 \times 28} \times 1.235 = 4.39 \text{ Ft / Sec}$

From table 21 considering the 6 row cooling coil, the water velocity of 4.39 Ft/Sec the pressure drop is given as 10.52 Ft. W.G.

-Determine the water side pressure drop (Heating Coil):

- Water flow rate (GPM) =  $\frac{\text{Total heating load}}{500 \times \Delta T} = \frac{726000}{500 \times 20} = 72.6 \text{ GPM}$

- Water velocity inside the tubes =  $\frac{\text{Water Flow Rate (GPM)}}{\text{No. of coils} \times \text{No. of circuits (Table 19)}} = 1.235 =$   
 $\frac{72.6}{1 \times 28} \times 1.235 = 3.2 \text{ Ft / Sec}$

From table 14 considering the 2 row heating coil, the water velocity of 3.2 Ft/Sec, the pressure drop is given 2.62 Ft w.g and a. The average water temp, of 170 F correction factor is 0.77 there fore, the actual P.D. is 2.02 Ft W.G.

### (D.X. COOLING, STEAM HEATING)

---

Given:

Require air flow rate = 9500 CFM

Cooling entering air condition = 80 °F DB , 67 °F WB

Heating entering air condition = 60 °F DB

Total cooling load = 450 MBH

Total heating load = 950 MBH

Cooling coil FPI = 14

Heating coil FPI = 8

Evaporating temperature = 45 °F

Steam pressure = 5 psi

External static pressure drop. = 0.5 in. WG

Maximum coil face velocity = 500 FPM

Filter arrangement = flat type

Considering the required air flow rate in cfm and the unit available nominal air flow rate, air handling model SRAH - 1000 is chosen.

-From table 3 @ the given wolfing capacity and the evap. temp. a 6-rows wiles chosen (wolfing capacity of units is 471 MBH)

-From table 6 @ the given heating capacity and the steam pressure of 5 psig , a 2-rows heating coil is cho (Heating capacity of the unit is 980 MBH)

Determine the actual coil face velocity.

$$\text{Actual F.V.} = \frac{\text{CFM}}{\text{F.A.}} = \frac{9500}{20} = 475 \text{ FPM}$$

Referring to the correction factors in table 12, the cooling and the heating capacity correction factors given as 0.97 And 0.98 Respectively.

-Corrected cooling capacity = 471 x 0.97 = 456.8 MBH

-Corrected heating capacity = 980 x 0.98 = 960.4 MBH

Therefore, the chosen cooling and heating coils satisfy the requirements.

-Knowing the actual coil face velocity and the coils chosen, determine the total internal air side pressure drop for the unit.

- P.D. DX coil = P.D. (Table 10) x C.F. (Table 10A) = 0.79 x 1.45 = 1.15 in W.G

- P.D. Heating coil = P.D. (Table 10) x C.F. (Table 10A) = 0.21 x 1 = 0.21 in W.G
- P.D. Filter = 0.09 in W.G (table 9)
- P.D. Accessories = 0.05 in W.G (table 11) Total internal pressure drop (T.I.P.D)

Total external pressure drop (T.E.P.D)

$$\begin{aligned} \text{T.I.P.D} &= \text{P.D. DX Coil} + \text{P.D. Heating coil} + \text{P. D. Filter accessories} \\ &= 1.15 + 0.2 + 0.09 + 0.05 = 1.5 \text{ in W.G} \end{aligned}$$

Total static pressure(T.S.P)= T.I.P.D + T.E.P.D =1.5 +0.5 = 2 in W.G

Therefore, by using table 1 and performing interpolation the required fan size is determined as 56 cm at the speed of 629 RPM and electric motor power requirement of 5.5kW.

Fan Performance (Forward Curved)

Table 1-A																
Model	Fan Quantity and Size (mm)	Coil Face area sq.ft²	FPM	CFM	Total static pressure in inches of water column											
					0.5"		1"		1.5"		2"		3"			
					RPM	kW	RPM	kW	RPM	kW	RPM	kW	RPM	kW		
AHU 250	1 x 315	5	400	2000	629	0.55	814	0.75	919	0.75	1006	0.75	1168	1.1	1222	1.0
			450	2250	702	0.55	811	0.75	916	0.75	1001	1.1	1168	1.1	1228	1.0
			500	2500	705	0.55	810	0.75	916	1.1	997	1.1	1158	1.5	1218	1.0
			550	2750	711	0.75	639	0.75	918	1.1	993	1.1	1153	2	1212	1.0
			600	3000	720	1.1	637	0.75	923	1.1	1005	1.5	1149	1.1	1211	1
			700	3500	740	1.1	833	1.5	941	1.1	1017	1.5	1025	3	1222	3
AHU 350	1 x 400	7	400	2800	554	0.55	638	1.1	716	1.5	785	1.5	908	1.1	1038	1.0
			450	3150	547	0.55	635	1.5	714	1.5	784	1.5	908	1.1	1038	1.0
			500	3500	546	1.1	633	1.5	711	1.5	781	2.2	906	3	1031	3
			550	3850	546	1.1	631	1.5	708	2.2	780	2.2	904	3	1028	3
			600	4200	639	1.1	630	2.2	706	2.2	775	2.2	901	3	1020	3
			700	4900	559	1.1	634	2.2	705	3	772	3	895	4	1010	4
AHU 500	1 x 450	10	400	4000	515	1.1	571	1.5	631	1.5	688	2.2	803	3	891	4
			450	4500	539	1.5	592	1.5	641	2.2	687	2.2	798	3	890	3
			500	5000	566	1.5	610	2.2	656	3	685	3	798	4	894	4
			550	5500	591	2.2	560	2.2	682	3	722	3	803	4	898	4
			600	6000	621	2.2	562	2.2	625	3	684	3	818	4	911	4
			700	7000	677	3	721	3	630	4	686	4	792	5.5	909	5.5
AHU 700	1 x 500	15	400	6000	474	1.5	530	2.2	543	3	648	3	748	4	781	4
			450	6750	491	2.2	542	3	593	3	645	3	750	4	780	4
			500	7500	512	3	560	3	605	3	651	4	755	5.5	781	5.5
			550	8200	533	3	580	4	621	4	664	4	757	7.8	788	5.5
			600	9000	557	4	601	4	642	4	681	5.5	757	5.5	791	7.5
			700	10500	--	--	646	5.5	684	5.5	722	7.5	791	7.5	800	10
AHU 1000	1 x 560	20	400	8000	401	3	448	3	497	4	545	4	627	5.5	732	5.5
			450	9000	418	3	459	4	502	4	548	5.5	630	7.5	732	7.5
			500	10000	436	4	475	4	513	5.5	551	5.5	638	7.5	732	7.5
			550	11000	457	4	493	5.5	528	5.5	563	7.5	640	7.5	732	7.5
			600	12000	478	5.5	512	5.5	546	7.5	577	7.5	641	11	732	10
			700	14000	525	7.5	554	7.5	585	11	614	11	669	11	749	11
AHU 1200	1 x 560	25	400	10000	357	3	394	4	443	4	482	5.5	563	7.5	632	7.5
			450	11250	373	4	405	4	450	5.5	484	5.5	555	7.5	632	7.5
			500	12500	391	5.5	422	5.5	483	5.5	493	7.5	554	7.5	632	7.5
			550	13750	428	5.5	440	7.5	478	7.5	500	7.5	560	11	632	11
			600	15000	432	7.5	459	7.5	496	11	522	10	572	11	631	11
			700	17500	474	10	499	10	533	15	554	15	600	11	600	10
AHU 1500	1 x 630	30	400	12000	362	4	396	4	430	5.5	464	5.5	536	7.5	632	7.5
			450	13500	382	5.5	413	5.5	444	7.5	474	7.5	538	11	632	11
			500	15000	404	5.5	434	7.5	461	7.5	488	7.5	542	11	632	11
			550	16500	427	7.5	454	7.5	481	11	506	11	555	15	632	15
			600	18000	458	11	477	11	502	11	526	15	571	15	602	15
			700	21000	--	--	524	15	547	15	569	15	610	15	610	15
AHU 1700	1 x 630	35	400	14000	327	4	358	5.5	389	5.5	422	7.5	489	11	632	11
			450	15750	344	5.5	372	7.5	400	7.5	428	7.5	484	11	632	11
			500	17500	363	7.5	389	7.5	414	11	439	11	490	15	630	10
			550	19250	382	11	405	11	431	11	453	15	500	15	630	15
			600	21000	413	11	425	15	448	15	470	15	512	15	632	15
			700	24500	425	15	466	15	486	21	506	21	534	15	606	15
AHU 2000	1 x 710	40	400	16000	336	5.5	364	7.5	391	7.5	419	11	475	11	631	11
			450	18000	357	7.5	383	7.5	408	11	432	11	482	15	608	15
			500	20000	379	11	403	11	427	15	449	15	494	15	602	15
			550	22000	403	15	425	15	447	15	469	15	509	21	602	21
			600	24000	--	--	448	15	469	15	489	21	537	21	600	21
			700	28000	--	--	514	25	533	25	533	30	567	30	571	30
AHU 2200	1 x 710	45	400	18000	289	5.5	317	7.5	344	11	371	11	429	15	608	15
			450	20250	305	7.5	330	7.5	354	11	379	11	428	15	602	15
			500	22500	322	11	345	11	361	15	390	15	433	15	602	15
			550	24750	340	11	363	15	383	15	403	15	443	21	602	21
			600	27000	359	15	381	15	400	15	419	21	456	21	631	21
			700	31500	--	--	415	20	436	25	453	30	486	30	612	30
800	36000	--	--	--	--	--	--	--	--	--	--	--	--			



Table 1-B																
Model	Fan Quantity and Size (mm)	Coil Face area sq.ft²	FPM	CFM	Total static pressure in inches of water column											
					0.75"		1"		1.25"		1.5"		2"		2.5"	
					RPM	kW	RPM	kW	RPM	kW	RPM	kW	RPM	kW	RPM	kW
AHU 2500	2 x 560	50	400	20000	442	2 x 4	480	2 x 4	517	2 x 5.5	554	2 x 5.5	629	2 x 7.5	724	2 x 7.5
			450	22500	468	2 x 5.5	504	2 x 5.5	538	2 x 5.5	571	2 x 7.5	637	2 x 11	727	2 x 7.5
			500	25000	497	2 x 5.5	530	2 x 7.5	562	2 x 7.5	592	2 x 7.5	651	2 x 11	737	2 x 7.5
			550	27500	528	2 x 7.5	557	2 x 11	587	2 x 11	616	2 x 11	672	2 x 15	747	2 x 11
			600	30000	--	--	587	2 x 11	615	2 x 11	642	2 x 15	694	2 x 15	761	2 x 11
			700	35000	--	--	--	--	675	2 x 15	698	2 x 21	746	2 x 21	800	2 x 15
800	40000	--	--	--	--	--	--	--	--	802	2 x 21	849	2 x 15			
AHU 3000	2 x 630	60	400	24000	362	2 x 4	396	2 x 4	430	2 x 5.5	464	2 x 5.5	536	2 x 7.5	627	2 x 7.5
			450	27000	382	2 x 5.5	413	2 x 5.5	444	2 x 7.5	474	2 x 7.5	535	2 x 11	627	2 x 11
			500	30000	404	2 x 5.5	434	2 x 7.5	461	2 x 7.5	488	2 x 7.5	542	2 x 11	627	2 x 11
			550	33000	427	2 x 7.5	454	2 x 7.5	481	2 x 11	506	2 x 11	555	2 x 15	627	2 x 15
			600	36000	458	2 x 11	477	2 x 11	502	2 x 11	526	2 x 15	571	2 x 15	627	2 x 15
			700	42000	--	--	524	2 x 15	547	2 x 15	569	2 x 15	610	2 x 21	671	2 x 21
AHU 3500	2 x 710	70	400	28000	317	2 x 4	348	2 x 5.5	379	2 x 5.5	412	2 x 7.5	479	2 x 11	566	2 x 11
			450	31500	334	2 x 5.5	362	2 x 7.5	390	2 x 7.5	418	2 x 7.5	474	2 x 11	566	2 x 11
			500	35000	353	2 x 7.5	379	2 x 7.5	404	2 x 11	429	2 x 11	480	2 x 15	566	2 x 15
			550	38500	371	2 x 11	397	2 x 11	421	2 x 11	443	2 x 15	489	2 x 15	566	2 x 15
			600	42000	393	2 x 11	415	2 x 15	438	2 x 15	460	2 x 15	502	2 x 15	566	2 x 15
			700	49000	415	2 x 15	456	2 x 15	476	2 x 21	496	2 x 21	534	2 x 21	594	2 x 21
AHU 4000	2 x 710	80	400	32000	336	2 x 5.5	364	2 x 7.5	391	2 x 7.5	419	2 x 11	475	2 x 11	566	2 x 11
			450	36000	357	2 x 7.5	383	2 x 7.5	408	2 x 11	432	2 x 11	482	2 x 15	566	2 x 15
			500	40000	379	2 x 11	403	2 x 11	427	2 x 15	449	2 x 15	494	2 x 15	566	2 x 15
			550	44000	403	2 x 15	425	2 x 15	447	2 x 15	469	2 x 15	509	2 x 21	566	2 x 21
			600	48000	--	--	448	2 x 15	469	2 x 15	489	2 x 21	537	2 x 21	566	2 x 21
			700	56000	--	--	--	--	514	2 x 21	533	2 x 21	567	2 x 30	567	2 x 30
AHU 4500	2 x 800	88	400	35200	289	2 x 5.5	317	2 x 7.5	344	2 x 11	371	2 x 11	414	2 x 11	524	2 x 11
			450	39600	305	2 x 7.5	330	2 x 7.5	354	2 x 11	379	2 x 11	417	2 x 11	524	2 x 15
			500	44000	322	2 x 11	345	2 x 11	361	2 x 15	390	2 x 15	433	2 x 15	524	2 x 15
			550	48400	340	2 x 11	363	2 x 15	383	2 x 15	403	2 x 15	443	2 x 21	524	2 x 21
			600	52800	359	2 x 15	381	2 x 15	400	2 x 11	419	2 x 21	456	2 x 21	524	2 x 21
			700	61600	--	--	415	2 x 21	436	2 x 11	453	2 x 25	486	2 x 30	524	2 x 30

Note : Selections in shaded areas not recommended for cooling applications .

Fan Performance (Backward Curved)

Table 1-C

Model	Fan Size	Coil Face area sq.ft²	FPM	CFM	Total static pressure in inches of water column											
					2.5"		3"		3.5"		4"		5"		6"	
					RPM	kW	RPM	kW	RPM	kW	RPM	kW	RPM	kW	RPM	kW
AHU 250	1 x 315	5	450	2000	1974	2.2	--	--	--	--	--	--	--	--	--	--
			500	2250	1971	2.2	1839	2.2	--	--	--	--	--	--	--	--
			550	2500	1968	2.2	1825	2.2	2271	3	--	--	--	--	--	--
			600	2750	--	--	--	--	--	--	--	--	--	--	--	--
AHU 350	1 x 40"	7	400	3000	2082	2.2	2215	3	2011	3	2470	5.5	--	--	--	--
			450	3150	--	--	--	--	--	--	--	--	--	--	--	--
			500	3500	1523	3	--	--	--	--	--	--	--	--	--	--
			550	3850	1553	3	1670	3	--	--	--	--	--	--	--	
AHU 500	1 x 45"	10	400	4000	1545	3	1773	4	1871	4	1967	5.5	2151	7.5	--	--
			450	4500	1345	3	1467	4	1583	4	1694	5.5	--	--	--	
			500	5000	1388	4	1495	4	1599	5.5	1693	5.5	--	--	--	
			550	5500	1421	4	1522	5.5	1620	5.5	1715	5.5	1899	7.5	--	--
AHU 700	1 x 50"	15	400	6000	1458	4	1554	5.5	1647	5.5	1738	7.5	1912	7.5	--	--
			450	6750	1267	5.5	1360	5.5	1450	7.5	1544	7.5	1959	11	--	--
			500	7500	1306	5.5	1393	5.5	1477	7.5	1560	7.5	--	--	--	
			550	8200	1349	5.5	1430	7.5	1510	7.5	1587	11	1767	15	--	--
AHU 1000	1 x 56"	20	400	8000	1147	7.5	1478	7.5	1553	11	1626	11	1767	15	--	--
			450	9000	1147	7.5	--	--	--	--	--	--	--	--	--	
			500	10000	1182	7.5	1261	7.5	--	--	--	--	--	--	--	
			550	11000	1223	7.5	1296	11	1369	11	--	--	--	--	--	
AHU 1200	1 x 63"	25	400	10000	890	7.5	--	--	--	--	--	--	--	--	--	--
			450	11250	1016	7.5	1090	11	--	--	--	--	--	--	--	
			500	12500	1049	7.5	1117	11	1185	15	--	--	--	--	--	
			550	13750	1087	11	1151	11	1213	15	1274	15	--	--	--	
AHU 1500	1 x 71"	30	400	12000	1270	11	1338	11	1405	15	1471	15	1666	20	--	--
			450	13500	899	11	969	11	--	--	--	--	--	--	--	
			500	15000	922	11	988	15	1052	15	--	--	--	--	--	
			550	16500	952	11	1012	15	1071	15	1130	18.5	--	--	--	
AHU 1700	1 x 71"	35	400	18000	985	15	1041	15	1096	18.5	1151	18.5	1258	18.5	--	--
			450	21000	1063	15	1111	18.5	1159	18.5	1206	18.5	1301	22	1394	22
			500	24000	1130	15	1135	15	1199	15	1259	15	1345	22	1414	22
			550	27000	1199	15	1161	15	1227	15	1287	15	1391	22	1462	22
AHU 2000	1 x 71"	40	400	24000	1130	15	1135	15	1199	15	1259	15	1345	22	1414	22
			450	28000	1199	15	1161	15	1227	15	1287	15	1391	22	1462	22
			500	32000	1259	15	1187	15	1254	15	1316	15	1423	22	1500	22
			550	36000	1328	15	1213	15	1281	15	1341	15	1459	22	1536	22
AHU 2200	1 x 71"	45	400	18000	985	15	1041	15	1096	18.5	1151	18.5	1258	18.5	--	--
			450	20250	1130	15	1135	15	1199	15	1259	15	1345	22	--	--
			500	22500	1199	15	1161	15	1227	15	1287	15	1391	22	--	--
			550	24750	1268	15	1187	15	1254	15	1316	15	1423	22	--	--
AHU 2500	2 x 71"	50	400	27000	1268	15	1187	15	1254	15	1316	15	1423	22	--	--
			450	31500	1328	15	1213	15	1281	15	1341	15	1459	22	--	--
			500	36000	1397	15	1239	15	1307	15	1369	15	1495	22	--	--
			550	40500	1466	15	1265	15	1333	15	1395	15	1531	22	--	--
AHU 3000	2 x 71"	60	400	36000	1397	15	1239	15	1307	15	1369	15	1495	22	--	--
			450	40500	1466	15	1265	15	1333	15	1395	15	1531	22	--	--
			500	45000	1535	15	1291	15	1359	15	1423	15	1567	22	--	--
			550	49500	1604	15	1317	15	1385	15	1459	15	1603	22	--	--
AHU 3500	2 x 71"	70	400	45000	1535	15	1291	15	1359	15	1423	15	1567	22	--	--
			450	49500	1604	15	1317	15	1385	15	1459	15	1603	22	--	--
			500	54000	1673	15	1343	15	1411	15	1495	15	1639	22	--	--
			550	58500	1742	15	1369	15	1437	15	1531	15	1675	22	--	--
AHU 4000	2 x 71"	80	400	54000	1673	15	1343	15	1411	15	1495	15	1639	22	--	--
			450	58500	1742	15	1369	15	1437	15	1531	15	1675	22	--	--
			500	63000	1811	15	1395	15	1463	15	1567	15	1711	22	--	--
			550	67500	1880	15	1421	15	1489	15	1603	15	1747	22	--	--
AHU 4500	2 x 71"	88	400	63000	1811	15	1395	15	1463	15	1567	15	1711	22	--	--
			450	67500	1880	15	1421	15	1489	15	1603	15	1747	22	--	--
			500	72000	1949	15	1447	15	1515	15	1639	15	1783	22	--	--
			550	76500	2018	15	1473	15	1541	15	1675	15	1819	22	--	--

Note : Selections in shaded areas not recommended for cooling applications

## Air Handling Unit – Dimensions

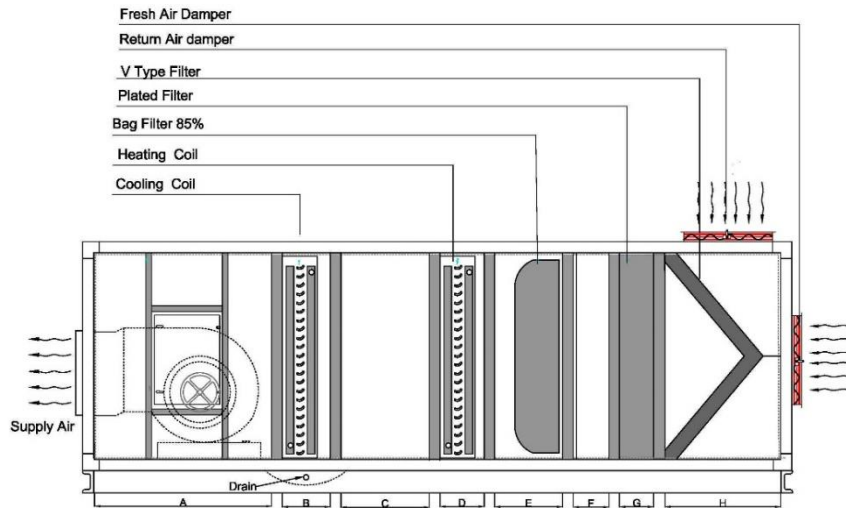
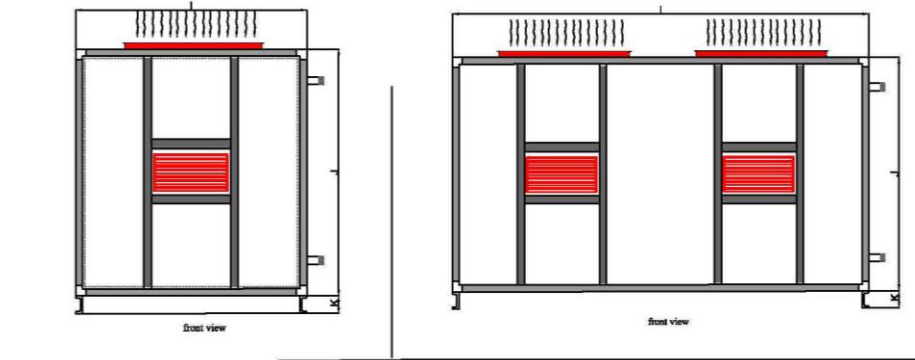

Model	A	B & D	C	E	F	G	H	I	J	K	Added Length			
AHU 250	1000	No. of Row	Coil Width	600	600	600	200	650	1000	920	80	200		
AHU 350	1150			600	600	600	200	700	1100	1020	80	200		
AHU 500	1200	1	100	600	600	600	200	800	1500	1120	80	250		
AHU 700	1300			600	600	600	200	900	1500	1320	80	250		
AHU 1000	1500			600	600	600	200	1000	2000	1400	100	300		
AHU 1200	1500			600	600	600	200	1100	2000	1600	100	300		
AHU 1500	1600			2	150	600	600	600	200	1300	2000	1900	100	300
AHU 1700	1600					600	600	600	200	1400	2250	1900	100	300
AHU 2000	1700			3	180	600	600	600	200	1300	2400	1980	120	300
AHU 2200	1700					600	600	600	200	1400	2400	2180	120	300
AHU 2500	1400			4	220	600	600	600	200	1200	3200	1780	120	300
AHU 3000	1600					600	600	600	200	1300	4000	1780	120	300
AHU 3500	1700	5	250	600	600	600	200	1350	4200	1880	120	300		
AHU 4000	1700			600	600	600	200	1400	4500	2000	120	300		
AHU 4500	1900	6	280	600	600	600	200	1800	5000	2100	120	300		
				600	600	600	200	1800	5000	2100	120	300		

**Note:**

- All Dimensions are in mm

For Air Handling Units with **HEPA filter** add 700 mm and also for each extra **BAG filter** add 1100 mm to mentioned dimensions

## Multi Zone Air Handling Unit

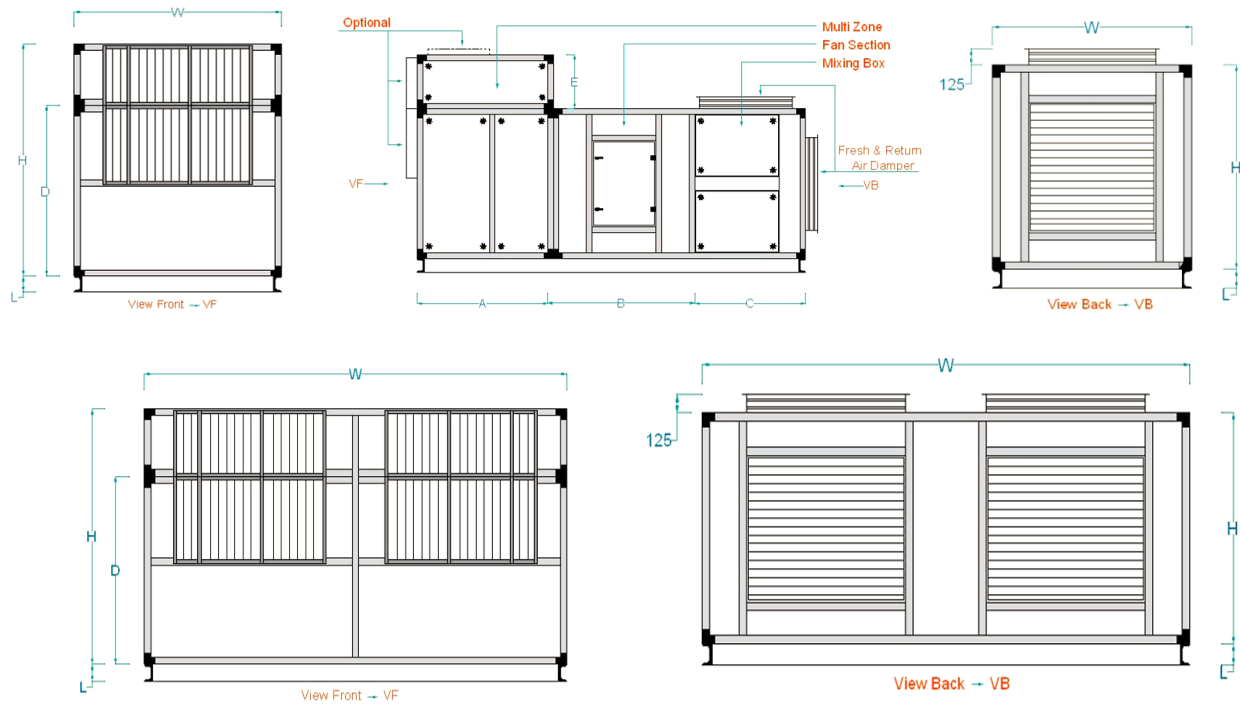

Dimensions								
Model	A	B	C	D	E	L	H	W
AHU 250	1150	1150	880	1050	250	80	1050	1050
AHU 350	1350	1200	880	1150	350	80	1150	1050
AHU 500	1350	1350	980	1300	450	80	1300	1500
AHU 700	1550	1400	1070	1400	450	100	1400	1500
AHU 1000	1600	1600	1070	1500	550	100	1500	2000
AHU 1200	1750	1800	1070	1700	550	100	1700	2000
AHU 1500	2000	1900	1270	2000	500	120	2000	2000
AHU 1700	2000	1900	1470	2000	600	120	2000	2250
AHU 2000	2000	2050	1470	2100	650	120	2100	2500
AHU 2200	2150	2050	1570	2100	700	120	2100	2650
AHU 2500	1750	1800	1070	1700	750	140	1700	4000
AHU 3000	2000	1900	1270	2000	850	140	2000	4000
AHU 3500	2000	1900	1470	2000	850	140	2000	4500
AHU 4000	2000	2050	1470	2100	850	140	2100	5000
AHU 4500	2150	2050	1570	2100	900	140	2100	5300

Note :

- All Dimensions are in mm

Table 4 Chilled Water Rating ( 8 FPI )															
Model	Nominal Air Flow Rate (CFM)	EDB (°F)	EWB (°F)	4 Rows				6 Rows				8 Rows			
				Total Load (MBH)	Sensible Load (MBH)	LVG DB (°F)	LVG WB (°F)	Total Load (MBH)	Sensible Load (MBH)	LVG DB (°F)	LVG WB (°F)	Total Load (MBH)	Sensible Load (MBH)	LVG DB (°F)	LVG WB (°F)
AHU 250	2500	80	67	59	54	61	60	88	68	57	56	110	78	53	53
		90	71	84	76	63	61	120	94	58	57	146	106	54	54
		100	75	111	98	66	63	154	119	59	58	184	133	54	54
AHU 350	3500	80	67	82	75	61	60	122	95	57	56	153	108	54	53
		90	71	117	106	64	61	168	131	58	57	204	147	54	54
		100	75	154	136	66	63	215	166	59	58	257	185	54	54
AHU 500	5000	80	67	140	116	60	58	198	145	55	55	238	163	52	52
		90	71	193	161	62	60	263	197	56	55	312	220	52	52
		100	75	249	205	64	61	333	248	57	56	388	273	53	53
AHU 700	7000	80	67	196	163	60	58	277	203	55	55	334	229	52	52
		90	71	270	226	62	60	369	276	56	55	436	307	52	52
		100	75	348	288	64	61	466	347	57	56	543	383	53	53
AHU 1000	10000	80	67	306	242	59	58	420	299	54	54	498	336	51	51
		90	71	414	334	61	59	552	404	55	55	643	448	52	52
		100	75	527	422	63	61	692	506	56	55	796	556	52	52
AHU 1200	12500	80	67	378	301	59	58	520	372	55	54	617	418	52	51
		90	71	512	414	62	59	684	502	56	55	798	557	52	52
		100	75	652	523	64	61	857	629	57	56	989	692	52	52
AHU 1500	1500	80	67	451	359	59	58	621	445	55	54	737	500	52	52
		90	71	609	494	62	59	816	600	56	55	954	667	52	52
		100	75	776	625	64	61	1023	752	57	56	1182	828	53	52
AHU 1700	17500	80	67	545	410	58	57	744	507	53	53	878	568	50	50
		90	71	736	564	60	58	977	684	54	54	1133	756	50	50
		100	75	936	675	62	60	1221	855	55	54	1403	940	50	50
AHU 2000	20000	80	67	652	501	58	57	875	614	54	53	1024	684	51	51
		90	71	750	638	62	60	1035	781	56	56	1229	871	53	53
		100	75	970	813	65	62	1310	983	58	57	1535	1088	53	53
AHU 2200	22500	80	67	732	540	58	57	983	663	53	52	1152	740	50	50
		90	71	978	738	60	58	1282	8990	53	53	1480	982	50	50
		100	75	1239	930	62	60	1600	1111	54	54	1824	1216	50	50
AHU 2500	25000	80	67	757	602	59	58	1041	745	55	54	1235	836	52	51
		90	71	1024	828	61	59	1368	1005	56	55	1596	1114	52	52
		100	75	1304	1047	64	61	1715	1258	57	56	1978	1384	52	52
AHU 3000	30000	80	67	902	719	59	58	1242	890	55	54	1475	1000	52	52
		90	71	1219	989	62	59	1632	1201	56	55	1908	1334	52	52
		100	75	1553	1251	64	61	2046	1504	57	56	2365	1657	53	52
AHU 3500	35000	80	67	1090	820	58	57	1488	1014	53	53	1756	1136	50	50
		90	71	1471	1128	60	58	1954	1368	54	54	2266	1512	50	50
		100	75	1871	1424	62	60	2442	1710	55	54	2806	1880	50	50
AHU 4000	40000	80	67	1305	1003	58	57	1750	1228	54	53	2048	1369	51	51
		90	71	1500	1277	62	60	2071	1562	56	56	2458	1743	53	53
		100	75	1941	1627	65	62	2620	1966	58	57	3070	2176	53	53
AHU 4500	45000	80	67	1464	1079	58	57	1966	1326	53	52	2304	1480	50	50
		90	71	1957	1475	60	58	2564	1780	53	53	2960	1964	50	50
		100	75	2478	1858	62	60	3200	2222	54	54	3648	2423	50	50

## Notes :

- Values based on entering chilled water temperature of 45 °F
- EDB = Entering air dry bulb temperature      -EWB = Entering air wet bulb temperature
- LVG = Leaving air temperature                      - MBH = 1000 BTU/hr

Table 5 Chilled Water Rating ( 14 FPI )															
Model	Nominal Air Flow Rate (CFM)	EDB (°F)	EWB (°F)	4 Rows				6 Rows				8 Rows			
				Total Load (MBH)	Sensible Load (MBH)	LVG DB (°F)	LVG WB (°F)	Total Load (MBH)	Sensible Load (MBH)	LVG DB (°F)	LVG WB (°F)	Total Load (MBH)	Sensible Load (MBH)	LVG DB (°F)	LVG WB (°F)
AHU 250	2500	80	67	72	59	58	58	104	73	53	53	125	82	50	50
		90	71	102	83	59	58	139	99	53	53	162	109	50	50
		100	75	132	106	60	59	175	124	54	53	200	136	50	50
AHU 350	3500	80	67	100	82	58	58	146	102	53	53	175	115	50	50
		90	71	141	115	59	59	194	138	53	53	227	153	50	50
		100	75	183	147	60	60	244	174	54	54	280	189	50	50
AHU 500	5000	80	67	177	131	56	55	237	158	51	51	274	175	48	48
		90	71	237	179	57	56	307	211	51	51	346	228	48	48
		100	75	300	226	58	57	380	261	51	51	422	281	48	48
AHU 700	7000	80	67	243	182	56	56	328	220	51	51	380	243	48	48
		90	71	327	249	57	56	425	293	51	51	481	318	48	48
		100	75	415	313	58	57	526	363	52	51	587	391	48	48
AHU 1000	10000	80	67	385	275	55	54	498	327	50	50	564	357	47	47
		90	71	506	371	56	55	663	431	50	50	707	464	47	47
		100	75	633	463	57	56	781	532	50	50	858	568	47	47
AHU 1200	12500	80	67	477	341	55	54	619	407	50	50	701	445	48	48
		90	71	626	460	56	55	791	537	50	50	881	579	47	47
		100	75	785	576	57	56	971	663	51	50	1070	709	47	47
AHU 1500	1500	80	67	569	408	55	54	741	487	50	50	839	532	48	48
		90	71	747	550	56	55	945	642	50	50	1053	693	47	47
		100	75	936	688	57	56	1160	793	51	51	1280	849	47	47
AHU 1700	17500	80	67	689	482	55	54	887	569	50	50	1003	625	47	47
		90	71	924	659	55	55	1155	761	50	50	1280	816	47	47
		100	75	1170	830	56	56	1432	946	50	50	1572	1007	47	47
AHU 2000	20000	80	67	689	482	55	54	887	569	50	50	1003	625	47	47
		90	71	924	659	55	55	1155	761	50	50	1280	816	47	47
		100	75	1170	830	56	56	1432	946	50	50	1572	1007	47	47
AHU 2200	22500	80	67	924	635	54	53	1171	744	49	49	1314	806	49	47
		90	71	1227	827	55	54	1512	990	49	49	1667	1058	47	47
		100	75	1547	1083	56	55	1873	1229	49	49	2042	1304	47	47
AHU 2500	25000	80	67	820	570	54	53	1036	671	49	49	1157	727	47	47
		90	71	1065	763	55	54	1310	879	49	49	1442	941	47	47
		100	75	1321	949	56	55	1599	1081	50	50	1743	1149	47	47
AHU 3000	30000	80	67	924	635	54	53	1171	744	49	49	1314	806	49	47
		90	71	1227	827	55	54	1512	990	49	49	1667	1058	47	47
		100	75	1547	1083	56	55	1873	1229	49	49	2042	1304	47	47
AHU 3500	35000	80	67	953	682	55	54	1238	813	50	50	1402	889	48	48
		90	71	1253	921	56	55	1582	1074	50	50	1761	1157	47	47
		100	75	1570	1152	57	56	1941	1325	51	50	2139	1417	47	47
AHU 4000	40000	80	67	1137	715	55	55	1481	973	50	50	1678	1064	48	48
		90	71	1494	1100	56	55	1889	1284	50	50	2106	1385	47	47
		100	75	1871	1377	57	56	2319	1585	51	51	2559	1697	47	47
AHU 4500	45000	80	67	1378	945	55	54	1775	1138	50	50	2006	1249	47	47
		90	71	1847	1318	55	55	2310	1522	50	50	2560	1632	47	47
		100	75	2339	1659	56	56	2864	1892	50	50	3144	2014	47	47

## Notes :

- Values based on entering chilled water temperature of 45 °F
- EDB = Entering air dry bulb temperature      -EWB = Entering air wet bulb temperature
- LVG = Leaving air temperature      - MBH = 1000 BTU/hr

Table 6 Hot Water Rating ( 8 FPI )										
Model	Nominal Air Flow Rate (CFM)	EDB (°F)	1 Rows		2 Rows		3 Rows		4 Rows	
			Capacity (MBH)	LVG DB (°F)	Capacity (MBH)	LVG DB (°F)	Capacity (MBH)	LVG DB (°F)	Capacity (MBH)	LVG DB (°F)
AHU 250	2500	0	126	42	211	73	281	100	330	120
		20	109	58	183	85	245	110	289	128
		40	92	73	155	67	209	119	248	135
		60	76	88	127	108	174	127	207	141
AHU 350	3500	0	175	42	293	72	391	99	461	119
		20	151	57	254	85	341	109	402	127
		40	128	73	215	97	292	118	345	160
		60	105	88	177	108	243	127	288	160
AHU 500	5000	0	262	44	438	76	576	103	673	122
		20	228	60	382	88	504	113	589	130
		40	195	75	326	100	433	122	507	137
		60	161	90	271	111	362	130	425	143
AHU 700	7000	0	536	44	614	76	807	103	942	122
		20	320	60	535	88	706	113	825	130
		40	273	75	457	100	606	122	710	137
		60	226	90	379	111	507	130	596	143
AHU 1000	10000	0	535	45	893	78	1166	104	1356	124
		20	467	60	781	90	1022	114	1190	131
		40	400	76	669	102	880	123	1025	138
		60	333	91	558	113	738	131	862	144
AHU 1200	12500	0	660	44	1104	77	1445	103	1683	122
		20	576	60	965	89	1266	113	1476	130
		40	493	75	827	101	1090	122	1272	137
		60	410	90	690	112	914	131	1070	144
AHU 1500	15000	0	784	44	1315	76	1723	102	2009	122
		20	685	60	1150	89	1510	112	1763	130
		40	587	75	986	101	1300	122	1518	137
		60	488	90	822	112	1090	130	1277	143
AHU 1700	17500	0	926	48	1549	81	2045	107	2356	124
		20	810	62	1356	91	1769	114	2069	128
		40	694	76	1164	101	1548	121	1782	133
		60	579	90	972	111	1303	128	1500	139
AHU 2000	20000	0	1091	46	111	79	2363	106	2739	125
		20	955	61	1593	91	2073	115	2404	132
		40	819	77	1368	103	1786	124	2073	139
		60	684	92	1145	114	1502	133	1746	145
AHU 2200	22500	0	1203	49	2014	82	2643	108	3047	124
		20	1053	63	1764	92	2322	115	2675	129
		40	904	77	1516	102	2004	122	2307	134
		60	755	91	1269	112	1688	129	1943	139
AHU 2500	25000	0	1320	44	2209	77	2890	103	3366	122
		20	1153	60	1931	89	2533	113	2953	130
		40	987	75	1655	101	2180	122	2544	137
		60	821	90	1381	112	1829	131	2140	144
AHU 3000	30000	0	1569	44	2631	76	3446	102	4019	122
		20	1371	60	2300	89	3021	112	3526	130
		40	1174	75	1972	101	2600	122	3037	137
		60	977	90	1645	112	2181	130	2555	143
AHU 3500	35000	0	1852	48	3098	81	4090	107	4712	124
		20	1620	62	2712	91	3592	114	4138	128
		40	1388	76	2228	101	3096	121	3564	133
		60	1158	90	1944	111	2606	128	3000	139
AHU 4000	40000	0	2183	46	3639	79	4726	106	2479	125
		20	1911	61	3187	91	4147	115	4809	132
		40	1639	77	2737	103	3573	124	4147	139
		60	1368	92	2290	114	3004	133	3492	145
AHU 4500	45000	0	2406	49	4028	82	5286	108	6094	124
		20	2106	63	3628	92	4644	115	5350	129
		40	1808	77	3032	102	4008	122	4614	134
		60	1510	91	2538	112	3376	129	3886	139

## Notes :

- Values based on entering chilled water temperature of 45 °F
- EDB = Entering air dry bulb temperature      -EWB = Entering air wet bulb temperature
- LVG = Leaving air temperature      - MBH = 1000 BTU/hr

Table 7 Hot Water Rating ( 14 FPI )										
Model	Nominal Air Flow Rate (CFM)	EDB (°F)	1 Rows		2 Rows		3 Rows		4 Rows	
			Capacity (MBH)	LVG DB (°F)	Capacity (MBH)	LVG DB (°F)	Capacity (MBH)	LVG DB (°F)	Capacity (MBH)	LVG DB (°F)
AHU 250	2500	0	176	60	274	97	346	127	390	145
		20	152	74	237	107	302	133	340	149
		40	128	87	201	115	258	139	291	153
		60	105	99	165	123	214	144	243	156
AHU 350	3500	0	245	60	381	97	483	126	544	145
		20	212	73	330	106	420	132	475	149
		40	179	86	280	115	359	138	407	153
		60	146	99	230	123	299	143	340	156
AHU 500	5000	0	368	63	571	102	710	130	793	148
		20	320	77	497	111	621	137	694	152
		40	273	90	424	120	532	142	596	156
		60	225	102	352	128	445	147	500	159
AHU 700	7000	0	516	63	799	102	995	130	1110	148
		20	449	77	696	111	869	137	971	152
		40	382	90	594	120	746	142	834	156
		60	316	102	493	128	624	147	700	159.6
AHU 1000	10000	0	752	64	1165	104	1438	132	1599	149
		20	656	78	1017	113	1259	138	1400	154
		40	561	91	871	122	1082	144	1205	157
		60	466	104	726	130	908	149	1013	161
AHU 1200	12500	0	829	64	1443	103	1786	131	1989	148
		20	811	77	1261	112	1564	138	1742	153
		40	693	91	1080	121	1344	143	1499	157
		60	576	103	900	129	1128	149	1260	160
AHU 1500	15000	0	1106	63	1722	102	2134	130	2379	148
		20	965	77	1504	112	1868	137	2083	152
		40	825	90	1288	121	1606	143	1793	156
		60	686	103	1073	129	1347	148	1507	160
AHU 1700	17500	0	1307	68	2028	106	2531	133	2787	146
		20	1142	80	1773	113	2219	136	2442	148
		40	978	91	1520	120	1911	140	2102	150
		60	814	102	1270	126	1608	144	1769	153
AHU 2000	20000	0	1537	66	2373	106	2910	134	3224	151
		20	1343	79	2076	115	2550	140	2824	155
		40	1151	93	1781	124	2195	146	2432	159
		60	960	105	1489	132	1845	151	2048	162
AHU 2200	22500	0	1699	69	2639	108	3270	134	3601	147
		20	1485	80	2307	114	2868	137	3156	149
		40	1273	92	1908	118	2472	141	2718	151
		60	1063	103	1657	127	2081	145	2289	153
AHU 2500	25000	0	1857	64	2887	103	3573	131	3979	148
		20	1623	77	2522	112	3128	138	3484	153
		40	1388	91	2160	121	2689	143	2998	157
		60	1153	103	1800	129	2256	149	2521	160
AHU 3000	30000	0	2213	63	3444	102	4268	130	4759	148
		20	1931	77	3008	112	3736	137	4167	152
		40	1651	90	2576	121	3212	143	3586	156
		60	1372	103	2147	129	2695	148	3015	160
AHU 3500	35000	0	2614	68	4056	106	5062	133	5574	146
		20	2284	80	3546	113	4438	136	4884	148
		40	1956	91	3040	120	3822	140	4204	150
		60	1628	102	2540	126	3216	144	3538	153
AHU 4000	40000	0	3074	66	4746	106	5821	134	6448	151
		20	2687	79	4152	115	5101	140	5649	155
		40	2302	93	3562	124	4391	146	4865	159
		60	1920	105	2978	132	3690	151	4090	162
AHU 4500	45000	0	3398	69	5278	108	6540	134	7202	147
		20	2970	80	4614	114	5736	137	6312	149
		40	2546	92	3816	118	4944	141	5436	151
		60	2126	103	3314	127	4162	145	4378	153

## Notes :

- Values based on entering chilled water temperature of 45 °F
- EDB = Entering air dry bulb temperature      -EWB = Entering air wet bulb temperature
- LVG = Leaving air temperature      - MBH = 1000 BTU/hr



Table 8 Steam Heating Ratings (12 FPI)						
Model	Nominal CFM	EDB (°F)	1 Rows		2 Rows	
			Capacity MBH	LVG DB °F	Capacity MBH	LVG DB °F
AHU 250	2500	0	184	67.8	326	120.2
		20	168	82	297	129.5
		40	153	96.34	270	139.5
		60	136	110.0	240	148.3
AHU 350	3500	0	274	72.2	295	130.3
		20	250	85.8	452	139
		40	227	99.8	410	147.9
		60	202	113.0	365	155.9
AHU 500	5000	0	366	67.5	665	122.5
		20	334	81.5	606	131.7
		40	303	95.8	551	141.5
		60	270	109.6	490	150.1
AHU 700	7000	0	509	67	923	121.5
		20	464	81	842	130.8
		40	421	95.4	756	139.5
		60	375	109.2	680	149.3
AHU 1000	10000	0	726	66.9	1331	122.6
		20	662	81	1213	131.8
		40	601	95.4	1102	141.5
		60	535	109.4	980	150.1
AHU 1200	12500	0	907	66.8	1663	122.5
		20	826	80.9	1516	131.7
		40	751	95.4	1378	141.6
		60	668	109.2	1225	150.3
AHU 1500	15000	0	1093	67.2	1996	122.6
		20	996	81.2	1819	131.7
		40	905	95.6	1654	141.6
		60	805	109.3	1470	150.1
AHU 1700	17500	0	1282	67	2332	122.9
		20	1168	81	2126	132.1
		40	1062	96	1932	141.8
		60	944	109	1718	150.5
AHU 2000	20000	0	1470	67.7	2668	122.9
		20	1340	81.7	2433	132.1
		40	1218	96.1	2210	141.8
		60	1083	109.9	1965	150.5
AHU 2200	22500	0	1562	64	2997	122
		20	1497	81	2733	132
		40	1657	107	2483	141
		60	1473	120	2208	150
AHU 2500	25000	0	1814	66.8	3327	122.6
		20	1654	80.9	3033	131.8
		40	1503	95.4	2756	141.6
		60	1336	109.2	2450	150.3
AHU 3000	30000	0	2186	67.1	3992	122.6
		20	1993	81.2	3639	131.8
		40	1811	95.6	3307	141.6
		60	1610	109.2	2940	150.1
AHU 3500	35000	0	2564	67	4664	122.9
		20	2336	81	4252	132.1
		40	6796	96	3864	141.8
		60	1888	109	3436	150.5
AHU 4000	40000	0	2941	67.7	5337	123
		20	2681	81.7	4865	132
		40	2436	96.1	4421	141.8
		60	2166	109.9	3930	152.5
AHU 4500	45000	0	3124	64	5994	122
		20	2994	81	5466	132
		40	3314	107	4966	141
		60	2946	120	4416	150

Notes :

- Values ratings based on steam of pressure 5PSIG.
- EDB = Entering air dry bulb temperature .
- MBH = 1000 BTU/hr.

Table 9 D.X Coil Rating ( 14 FPI )											
Model	Nominal Air Flow Rate (CFM)	EDB (°F)	EWB (°F)	4 Rows				6 Rows			
				Total Load (MBH)	Sensible Load (MBH)	LVG DB (°F)	LVG WB (°F)	Total Load (MBH)	Sensible Load (MBH)	LVG DB (°F)	LVG WB (°F)
AHU 250	2500	80	67	89	62	57	55	118	78	51	50
		90	71	102	79	61	58	137	99	54	52
		100	75	117	96	65	60	157	119	56	55
AHU 350	3500	80	67	123	86	57	55	163	109	51	50
		90	71	147	112	60	57	196	140	53	52
		100	75	162	134	65	61	217	166	57	55
AHU 500	5000	80	67	178	125	57	55	237	157	51	50
		90	71	205	159	61	58	274	198	54	52
		100	75	235	193	65	60	315	239	56	55
AHU 700	7000	80	67	250	175	57	55	332	221	51	50
		90	71	288	223	61	58	384	277	54	52
		100	75	329	270	65	60	441	334	56	55
AHU 1000	10000	80	67	354	249	57	55	471	314	51	50
		90	71	408	317	61	58	545	395	54	52
		100	75	467	384	65	61	626	476	56	55
AHU 1200	12500	80	67	434	307	57	55	578	387	51	50
		90	71	500	391	61	58	668	488	54	53
		100	75	572	474	65	61	767	588	57	55
AHU 1500	15000	80	67	513	365	57	55	684	460	52	51
		90	71	591	465	61	58	791	580	54	53
		100	75	676	564	65	61	908	700	57	55
AHU 1700	17500	80	67	583	477	59	57	813	602	53	51
		90	71	666	588	63	60	929	737	55	54
		100	75	726	700	67	64	1069	872	59	67
AHU 2000	20000	80	67	718	503	57	55	953	634	51	50
		90	71	827	639	61	57	1103	797	53	52
		100	75	946	774	65	60	1267	960	56	54
AHU 2200	22500	80	67	756	616	54	53	1054	718	52	51
		90	71	864	760	61	60	1204	951	56	55
		100	75	962	839	66	64	1385	1027	58	57
AHU 2500	25000	80	67	868	615	57	55	1156	775	51	50
		90	71	1000	782	61	58	1337	976	54	53
		100	75	1144	949	65	61	1535	1177	57	55
AHU 3000	30000	80	67	1027	730	57	55	1369	921	52	51
		90	71	1182	930	61	58	1583	1160	54	53
		100	75	1352	1129	65	61	1817	1400	57	55
AHU 3500	35000	80	67	1166	953	59	57	1326	1204	53	51
		90	71	1332	1176	63	60	1858	1474	55	54
		100	75	1452	1400	67	64	2138	1744	59	57
AHU 4000	40000	80	67	1436	1007	57	55	1907	1268	51	50
		90	71	1655	1278	61	57	2207	1594	53	52
		100	75	1893	1549	65	60	2534	1920	56	54
AHU 4500	45000	80	67	1512	1232	54	53	2108	1436	52	51
		90	71	1728	1520	61	60	2408	1902	56	55
		100	75	1924	1678	66	64	2770	2054	58	57

Notes :

- Values based in evaporating of refrigerant at 45 °F
- EDB = Entering air dry bulb temperature
- EWB = Entering air wet bulb temperature
- LVG = Leaving air temperature
- MBH = 1000 BTU / hr

Table 10 Hot Water Rating , Multi Zone										
Model	Nominal Air Flow Rate (CFM)	EDB (°F)	8 Fpi				14 Fpi			
			1 Rows		2 Rows		1 Rows		2 Rows	
			Capacity (MBH)	LVG DB (°F)	Capacity (MBH)	LVG DB (°F)	Capacity (MBH)	LVG DB (°F)	Capacity (MBH)	LVG DB (°F)
AHU 250	2500	0	110	36	188	64	155	53	249	88
		20	95	53	163	78	134	67	216	98
		40	80	69	138	90	113	81	182	108
		60	66	84	113	103	93	95	150	117
AHU 350	3500	0	159	38	270	66	225	54	357	90
		20	138	54	235	80	194	69	309	100
		40	116	70	199	92	164	82	262	110
		60	95	85	164	104	134	96	215	119
AHU 500	5000	0	238	39	402	69	335	57	532	94
		20	205	55	350	82	292	71	463	104
		40	175	71	299	95	248	85	395	114
		60	145	87	249	107	205	98	327	123
AHU 700	7000	0	328	39	560	69	465	56	740	93
		20	286	55	487	82	405	71	644	104
		40	243	71	417	94	345	85	549	113
		60	201	86	345	106	285	98	455	122
AHU 1000	10000	0	478	40	813	70	680	58	1080	96
		20	417	56	711	83	593	72	942	106
		40	357	72	609	96	507	86	808	116
		60	297	87	508	108	421	99	672	124
AHU 1200	12500	0	602	40	1023	71	857	58	1357	96
		20	527	56	895	84	748	73	1185	106
		40	450	72	768	96	639	86	1015	116
		60	375	88	640	108	531	100	846	125
AHU 1500	15000	0	706	39	1204	69	1007	57	1603	94
		20	617	55	1055	83	878	72	1400	105
		40	528	71	902	95	750	85	1198	115
		60	439	87	753	107	624	99	998	124
AHU 1700	17500	0	837	44	1425	75	1193	62	1896	100
		20	732	58	1248	85	1043	75	1657	107
		40	628	73	1070	96	892	88	1420	114
		60	523	87	892	107	744	99	1185	122
AHU 2000	20000	0	968	40	1647	71	1380	59	2189	97
		20	847	57	1442	84	1209	73	1915	107
		40	728	72	1239	97	1035	87	1642	117
		60	607	88	1032	109	864	100	1373	126
AHU 2200	22500	0	1086	44	1846	75	1547	63	2451	88
		20	950	59	1616	86	1352	75	2142	107
		40	814	73	1387	96	1156	87	1836	115
		60	678	84	1156	107	963	99	1532	122
AHU 2500	25000	0	1204	40	2046	71	1714	58	2714	96
		20	1054	56	1790	84	1496	73	2370	106
		40	900	72	1536	96	1278	86	2030	116
		60	750	88	1280	108	1062	100	1692	125
AHU 3000	30000	0	1412	39	2408	69	2014	57	3206	94
		20	1234	55	2110	83	1756	72	2800	105
		40	1056	71	1804	95	1500	85	2396	115
		60	878	87	1506	107	1248	99	1996	124
AHU 3500	35000	0	1674	44	2850	75	2386	62	3792	100
		20	1464	58	2496	85	2086	75	3314	107
		40	1256	73	2140	96	1784	88	2840	114
		60	1046	87	1784	107	1488	99	2370	122
AHU 4000	40000	0	1936	40	3294	71	2760	59	4378	97
		20	1694	57	2884	84	2418	73	3830	107
		40	1456	72	2478	97	2070	87	3284	117
		60	1214	88	2064	109	1728	100	2746	126
AHU 4500	45000	0	2172	44	3692	75	3094	63	4902	88
		20	1900	59	3232	86	2704	75	4284	107
		40	1628	73	2774	96	2312	87	3674	115
		60	1356	84	2312	107	1926	99	3064	122

## Notes :

- Hot water Entering : 180 °F & Leaving : 160 °F
- EDB = Entering air dry bulb Temperature .
- LVG = Leaving air Temperature .
- MBH = 1000 Btu/hr

Table 11 Steam Heating Ratings , Multi Zone (12FPI)						
Model	Nominal Air Flow Rate (CFM)	EDB (°F)	1 Rows		2 Rows	
			Capacity (MBH)	LVG DB (°F)	Capacity (MBH)	LVG DB (°F)
AHU 250	2500	0	165	61	293	108.1
		20	151	75.7	267	118.5
		40	137	90.7	243	129.5
		60	122	105.1	216	139.6
AHU 350	3500	0	246	65	445	117.3
		20	225	79.5	406	127.1
		40	204	93.7	369	137.1
		60	181	107.8	328	146.5
AHU 500	5000	0	329	60.7	598	110.3
		20	300	75.4	545	120.5
		40	272	90.2	495	131.4
		60	243	104.8	441	141.2
AHU 700	7000	0	458	60.3	830	109.3
		20	417	74.9	757	119.7
		40	378	89.8	680	129.5
		60	337	104.4	612	140.5
AHU 1000	10000	0	653	60.2	1197	110.4
		20	595	74.9	1091	120.6
		40	540	89.8	991	131.4
		60	481	104.3	882	141.3
AHU 1200	12500	0	816	60.1	1496	110.3
		20	743	74.8	1364	120.6
		40	675	89.8	1240	131.4
		60	601	104.3	1102	141.3
AHU 1500	15000	0	983	60.4	1796	110.3
		20	896	75	1637	120.5
		40	814	90	1488	131.4
		60	724	104.5	1323	141.3
AHU 1700	17500	0	1153	60	2099	110
		20	1051	75	1913	120
		40	955	90	1739	131
		60	849	104	1546	141
AHU 2000	20000	0	1323	60.9	2401	110.6
		20	1206	75.5	2189	120.9
		40	1096	90.5	1989	131.6
		60	974	104.9	1768	141.4
AHU 2200	22500	0	1478	60	2698	110
		20	1347	75	2459	120
		40	1224	90	2235	131
		60	1088	104	1987	141
AHU 2500	25000	0	1632	60.1	2994	110.3
		20	1488	74.8	2729	120.6
		40	1352	89.8	2480	131.4
		60	1202	104.3	2205	141.3
AHU 3000	30000	0	1967	60.5	3592	110.3
		20	1793	75.1	3275	120.6
		40	1629	90	2976	131.4
		60	1449	104.5	2646	141.3
AHU 3500	35000	0	2306	60	4198	110
		20	2102	75	3826	120
		40	1910	90	3478	131
		60	1698	104	3092	141
AHU 4000	40000	0	2646	60.9	4803	110.6
		20	2412	75.5	4378	120.8
		40	2192	90.5	3978	131.6
		60	1949	104.9	3537	141.5
AHU 4500	45000	0	2956	60.9	5396	110.6
		20	2694	75.5	4918	120.8
		40	2448	90.5	4470	131.6
		60	2176	104.9	3974	141.5

## Notes :

- Values ratings based on pressure of steam 5PSIG.
- EDB = Entering air dry bulb temperature .
- MBH = 1000 BTU /hr
-

Model	Nominal Air Flow Rate (CFM)	Coils				Filters Face Area			
		No of coil x No of circuits	Face HGT mm	Face LGT mm	Face Area ft <sup>2</sup>	Flat Type ft <sup>2</sup>	V Type ft <sup>2</sup>	Z Type ft <sup>2</sup>	W Type ft <sup>2</sup>
AHU 250	2500	1 x 16	600	790	5	5	8.5	10	12
AHU 350	3500	1 x 22	825	790	7.5	7.5	12	14	18
AHU 500	5000	1 x 20	750	1240	10	10	17	20	25
AHU 700	7000	1 x 28	1050	1240	14	14	23	27	34
AHU 1000	10000	1 x 28	1050	1740	20	20	33	39	50
AHU 1200	12500	2 x 18	1350	1740					
AHU 1500	15000	2 x 21	1575	1740	30	30	50	60	75
AHU 1700	17500	2 x 22	1650	1990					
AHU 2000	20000	2 x 22	1650	2240	45	45	73	87	117
AHU 2200	22500	2 x 23	1725	2390					
AHU 2500	25000	4 x 18	1350	2 x 1740	50	50	65	85	114
AHU 3000	30000	4 x 21	1575	2 x 1740	60	60	75	98	133
AHU 3500	35000	4 x 22	1650	2 x 1990					
AHU 4000	40000	4 x 22	1650	2 x 2240	80	80	100	130	176
AHU 4500	45000	4 x 23	1725	2 x 2390					

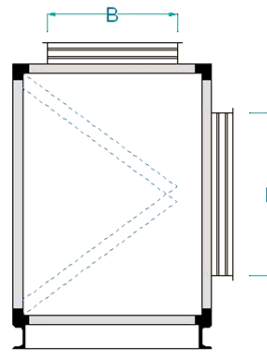
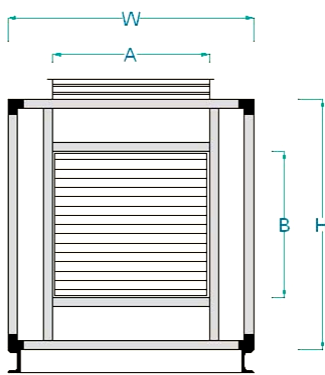

W-Z-V Type Filters

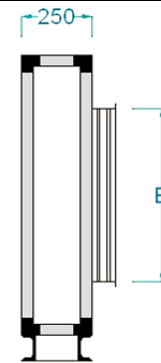

Flat Type Filters

Model	A	B	BB	H	W
AHU 250	700	200	400	820	1000
AHU 350	800	200	400	920	1100
AHU 500	1000	300	300	1120	1500
AHU 700	1200	400	800	1320	1500
AHU 1000	1300	400	800	1400	2000
AHU 1200	1300	400	800	1600	2000
AHU 1500	1700	500	1000	1900	2000
AHU 1700	1800	500	1000	1900	2250
AHU 2000	2000	500	1000	1980	2400
AHU 2200	2000	500	1000	2180	2400
AHU 2500	2 x 1250	400	800	1780	3200
AHU 3000	2 x 1700	500	1000	1780	4000
AHU 3500	2 x 180	500	1000	1880	4200
AHU 4000	2 x 1900	500	1000	2000	4500
AHU 4500	2 x 2000	500	1000	2100	5000

BB is according to 50% fresh air & 50% return air

If 100% fresh air & 100% return air is required, dampers size will be according to BB

Table 14-A												
Model	Water Velocity Feet Per Sec. 1 Row											
	0.5	1	1.5	2	2.5	3	3.5	4	5	6	7	8
AHU 250 , 350	0.11	0.29	0.53	0.8	1.13	1.44	1.82	2.22	3.04	4	4.95	6.06
AHU 500 , 700	0.14	0.36	0.65	0.95	1.35	1.75	2.2	2.7	3.7	4.75	5.9	7.3
AHU 1000 , 1200 , 1500 , 2500 , 3000	0.16	0.42	0.75	1.02	1.6	2.08	2.62	3.16	4.38	5.73	7.17	8.85
AHU 1700 , 3500	0.17	0.45	0.8	1.2	1.7	2.25	2.8	3.4	4.7	6.2	7.7	9.25
AHU 2000 , 4000	0.2	0.49	0.88	1.3	1.85	2.43	3.03	3.67	5.1	6.68	8.36	10.3 2
AHU 2200 , 4500	0.18	0.5	0.9	1.35	1.9	2.5	3.15	3.8	5.3	6.9	8.7	10.7

Table 14-B												
Model	Water Velocity Feet Per Sec. 2 Row											
	0.5	1	1.5	2	2.5	3	3.5	4	5	6	7	8
AHU 250 , 350	0.13	0.34	0.62	0.92	1.31	1.7	2.14	2.61	3.58	4.68	5.82	7.12
AHU 500 , 700	0.15	0.41	0.75	1.1	1.56	2.04	2.55	3.12	4.3	5.57	6.9	8.54
AHU 1000 , 1200 , 1500 , 2500 , 3000	0.18	0.49	0.88	1.29	1.85	2.4	2.95	3.66	5.13	6.7	8.38	10.35
AHU 1700 , 3500	0.2	0.53	0.95	1.42	2.01	2.63	3.3	4	5.55	7.25	9.5	11.2
AHU 2000 , 4000	0.21	0.57	1.02	1.51	2.05	2.83	3.54	4.28	5.97	7.81	9.78	12.07
AHU 2200 , 4500	0.21	0.58	1.05	1.56	2.25	2.95	3.7	4.45	6.2	8.81	10.2	12.06

Table 14-C												
Model	Water Velocity Feet Per Sec. 3 Row											
	0.5	1	1.5	2	2.5	3	3.5	4	5	6	7	8
AHU 250 , 350	0.17	0.45	0.82	1.23	1.74	2.26	2.86	3.52	4.82	6.3	7.85	9.66
AHU 500 , 700	0.21	0.55	1	1.48	2.13	2.8	3.48	4.3	5.9	7.7	9.65	11.95
AHU 1000 , 1200 , 1500 , 2500 , 3000	0.24	0.67	1.16	1.8	2.54	3.33	4.21	5.15	7.15	9.37	11.7	14.15
AHU 1700 , 3500	0.26	0.73	1.3	1.95	2.75	3.6	4.55	5.6	7.8	10.2	12.7	15.75
AHU 2000 , 4000	0.28	0.79	1.4	2.07	2.98	3.9	4.93	6.05	8.4	11.05	13.8	16.7
AHU 2200 , 4500	0.29	0.85	1.45	2.15	3.1	4.1	5.15	6.3	8.75	11.5	14.4	17.85

Table 14-D												
Model	Water Velocity Feet Per Sec. 4 Row											
	0.5	1	1.5	2	2.5	3	3.5	4	5	6	7	8
AHU 250 , 350	0.21	0.56	1.02	1.51	2.17	2.83	3.57	4.42	6.05	7.9	9.92	12.2
AHU 500 , 700	0.26	0.7	1.25	1.87	2.7	3.5	4.4	5.45	7.45	9.8	12.25	15.2
AHU 1000 , 1200 , 1500 , 2500 , 3000	0.29	0.85	1.51	2.23	3.21	4.22	5.36	6.6	9.15	12	15	18.63
AHU 1700 , 3500	0.32	0.93	1.65	2.45	3.5	4.6	5.8	7.2	10	13.1	16.4	20.3
AHU 2000 , 4000	0.35	1.01	1.78	2.62	3.81	4.98	6.32	7.76	10.83	14.24	17.83	22.09
AHU 2200 , 4500	0.36	1.06	1.85	2.72	3.96	5.22	6.6	8.1	11.3	14.85	18.6	23.1

Table 14-E												
Model	Water Velocity Feet Per Sec. 6 Row											
	0.5	1	1.5	2	2.5	3	3.5	4	5	6	7	8
AHU 250 , 350	0.29	0.8	1.44	2.13	3.08	4.03	5.05	6.2	8.54	11.28	14.07	17.35
AHU 500 , 700	0.36	0.98	1.8	2.65	3.83	5	6.3	7.77	10.7	14.14	17.78	21.93
AHU 1000 , 1200 , 1500 , 2500 , 3000	0.43	1.18	2.19	3.2	4.7	6.11	7.73	8.8	13.21	17.4	22.9	27.04
AHU 1700 , 3500	0.48	1.3	2.4	3.5	5.1	7.65	8.4	10.35	14.4	19	24	30
AHU 2000 , 4000	0.52	1.39	2.56	3.78	5.53	7.25	9.15	11.26	15.66	20.7	26.11	32.2
AHU 2200 , 4500	0.54	1.45	2.7	3.95	5.8	7.6	9.65	11.8	16.5	21.7	27.44	33.75

Table 14-F												
Model	Water Velocity Feet Per Sec. 8 Row											
	0.5	1	1.5	2	2.5	3	3.5	4	5	6	7	8
AHU 250 , 350	0.38	1.04	1.86	2.73	3.97	5.23	6.53	7.98	11.03	14.65	18.22	22.5
AHU 500 , 700	0.46	1.23	2.28	3.41	4.98	6.57	8.22	10.1	13.96	18.48	23.05	28.6
AHU 1000 , 1200 , 1500 , 2500 , 3000	0.57	1.51	2.82	4.18	6.1	8	10.1	12.4	17.37	22.81	28.85	35.4
AHU 1700 , 3500	0.64	1.64	3.1	4.55	6.65	8.7	11	13.55	18.9	24.9	31.5	38.8
AHU 2000 , 4000	0.69	1.78	3.35	4.95	7.25	9.52	12	14.76	20.5	27.16	34.4	42.31
AHU 2200 , 4500	0.71	1.85	3.5	5.2	7.65	10	12.7	15.5	21.6	28.6	36.3	44.4

### Coil Water Side Pressure Drop Correction Factor Temperature Gradient

Table 14-G												
Average Water Temperature ° F	40	50	60	80	100	120	140	150	160	180	200	220
Correction Factor	1.04	1	0.96	0.9	0.86	0.83	0.8	0.78	0.77	0.76	0.74	0.73

Connection Size

Table 15 Chilled & Hot water & Steam coil Connection											
Model	Chilled Water			Hot Water				Steam			
	4 Row	6 Row	8 Row	1 Row	2 Row	3 Row	4 Row	Inlet		Outlet	
								1 Row	2 Row	1 Row	2 Row
AHU 250	1 ¼"	1 ½"	1 ½"	1"	1"	1 ¼"	1 ¼"	1 ½"	1 ½"	1 ¼"	1 ¼"
AHU 350	1 ½"	2 "	2 "	1 ¼"	1 ¼"	1 ½"	1 ½"	1 ½"	1 ½"	1 ¼"	1 ¼"
AHU 500	1 ½"	2 "	2 "	1 ¼"	1 ¼"	1 ½"	1 ½"	2 "	2 "	1 ½"	1 ½"
AHU 700	2 "	2 "	2 ½"	1 ½"	1 ½"	2 "	2 "	2 "	2 "	1 ½"	1 ½"
AHU 1000	2 "	2 ½"	2 ½"	1 ½"	1 ½"	2 "	2 "	2 "	2 "	1 ½"	1 ½"
AHU 1200	2*2"	2*2 "	2*2 ½"	2*2 ½"	2*2 ½"	Ƴ*2"	Ƴ*2"	Ƴ*2"	Ƴ*2"	2*2 ½"	2*2 ½"
AHU 1500	2*2"	2*2 "	2*2 ½"	2*2 ½"	2*2 ½"	Ƴ*2"	Ƴ*2"	Ƴ*2"	Ƴ*2"	2*2 ½"	2*2 ½"
AHU 1700	2*2 ½"	2*2 ½"	2*2 ½"	2*2 ½"	2*2 ½"	Ƴ*2"	2*2 ½"	Ƴ*2"	Ƴ*2"	2*2 ½"	2*2 ½"
AHU 2000	2*2 ½"	2*2 ½"	2*2 ½"	2*2 ½"	2*2 ½"	Ƴ*2"	2*2 ½"	Ƴ*2"	Ƴ*2"	2*2 ½"	2*2 ½"
AHU 2200	2*2 ½"	2*2 ½"	2*2 ½"	2*2 ½"	2*2 ½"	Ƴ*2"	2*2 ½"	Ƴ*2"	Ƴ*2"	2*2 ½"	2*2 ½"
AHU 2500	4*2"	4*2 "	4*2 ½"	4*2 ½"	4*2 ½"	Ƴ*2"	Ƴ*2"	Ƴ*2"	Ƴ*2"	4*2 ½"	4*2 ½"
AHU 3000	4*2"	4*2 "	4*2 ½"	4*2 ½"	4*2 ½"	Ƴ*2"	Ƴ*2"	Ƴ*2"	Ƴ*2"	4*2 ½"	4*2 ½"
AHU 3500	4*2 ½"	4*2 ½"	4*2 ½"	4*2 ½"	4*2 ½"	Ƴ*2"	4*2 ½"	Ƴ*2"	Ƴ*2"	4*2 ½"	4*2 ½"
AHU 4000	4*2 ½"	4*2 ½"	4*2 ½"	4*2 ½"	4*2 ½"	Ƴ*2"	4*2 ½"	Ƴ*2"	Ƴ*2"	4*2 ½"	4*2 ½"
AHU 4500	4*2 ½"	4*2 ½"	4*2 ½"	4*2 ½"	4*2 ½"	Ƴ*2"	4*2 ½"	Ƴ*2"	Ƴ*2"	4*2 ½"	4*2 ½"

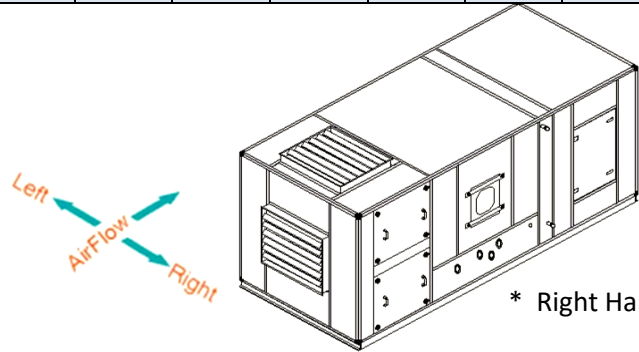

\* Right Handed Connection Are Shown

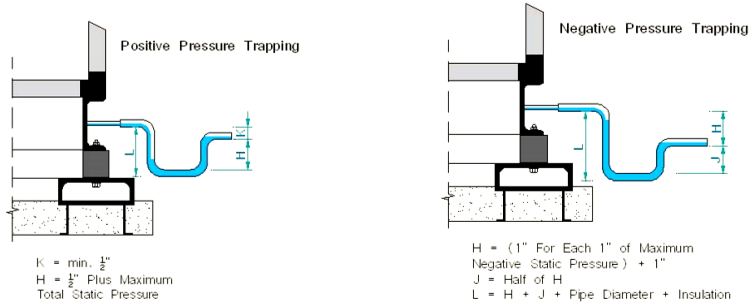

Drain Pan Trapping



## Coil Connection Details

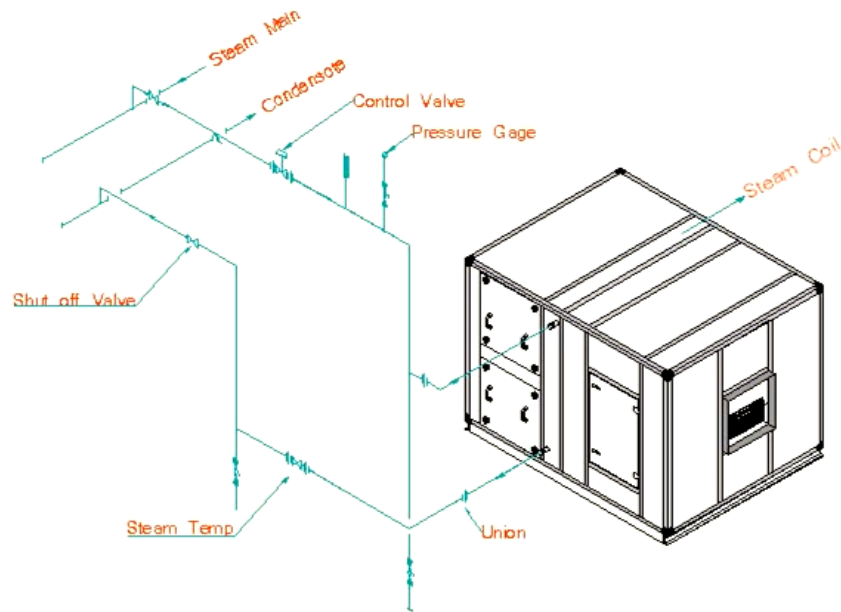

Suggested Coils Connection Details For Steam Coils

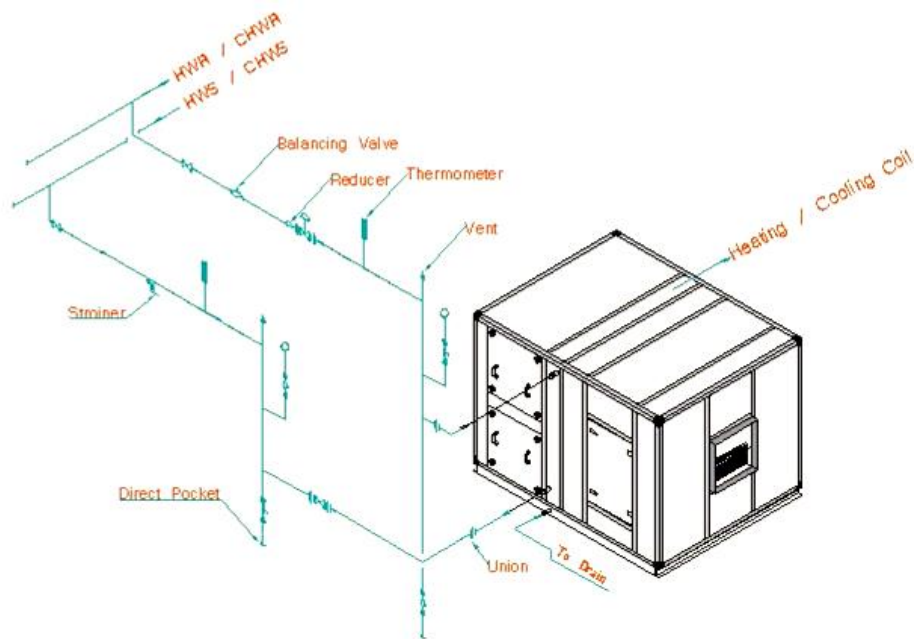

Suggested Coil Connection Details For Heating and Cooling Coil

Table 16 Filter Air Pressure Drop (in.w.g)										
Filters	Face Velocity FPM									
	300	350	400	450	500	550	600	650	700	800
Cleanable	0.037	0.050	0.065	0.081	0.099	0.120	0.156	0.182	0.235	0.325

Table 17 -A Air Side Coil Pressure Drop (in.w.g)										
Fin Per Inch	Rows Deep	Face Velocity FPM								
		300		400		500		600	700	800
		Dry	Wet	Dry	Wet	Dry	Wet	Dry	Dry	Dry
8	1	0.05	0.07	0.07	0.1	0.10	0.14	0.14	0.19	0.22
	2	0.09	0.14	0.15	0.2	0.22	0.29	0.3	0.39	0.48
	3	0.11	0.2	0.16	0.31	0.28	0.44	0.39	0.5	0.62
	4	0.15	0.25	0.24	0.4	0.35	0.58	0.48	0.61	0.77
	6	0.24	0.39	0.34	0.61	0.52	0.85	0.71	0.92	1.15
	8	0.30	0.5	0.47	0.82	0.71	1.05	0.95	1.18	1.46

Table 17-B PD Correction Factor			
Coil Fpi			
8	10	12	14
1	1.16	1.32	1.45

Notes :

In order to determine air-side coil pressure drop for cases where the number of fins per inch are greater than 8 Fpi , multiply the values by the corresponding correction factor given in the table above.

## AIR SIDE PRESSURE DROP ACCESSORIES (IN.W.G)

Table 18 ( At 500 FPM Velocity )									
Model	Diffuser	Air Washer		Face & By pass Damper	Damper	Mixing Box without Filter	Electrical Heater	Eliminator	Back Draft Damper
		Class 4	Class 6 , 8						
250 - 1200	0.03	0.22	0.4	0.21	0.05	0.06	0.02	0.1	0.2
1500 - 4500	0.04	0.25	0.45	0.25					

Table 19 Velocity Correction Factor								
Coil Face Velocity	350	400	450	500	550	600	700	800
Cooling Coil	0.8	0.88	0.94	1.0	1.05	1.11	1.19	1.28
Heating Coil	0.86	0.92	0.96	1.0	1.03	1.06	1.11	1.15

Table 20 FPI Correction Factor			
No. Of Rows	Fin Per Inch		
	8	10	12
4	1	1.1	1.19
6	1	1.08	1.15
8	1	1.06	1.1

Note :

In order to determine capacity of coils with 10 or 12 Fpi , multiply the capacity relative to 8 Fpi by the corresponding correction factor given in the table 17 .

Table 21 Correction Factor For Ethylene Glycol Mixture			
Mixture ( by Weight )		Freezing Point	Correction Factor For Cooling Capacity
Water	Ethylene Glycol		
100	0	0	1
90	10	- 4	1.02
85	15	- 6.1	1.03
80	20	- 9	1.05
75	25	- 12	1.07
70	30	-15	1.09
65	35	-19	1.11
60	40	- 24	1.14
55	45	-29.4	1.17
50	50	-36.1	1.2
45	55	- 45	1.23

Flow Rate = GPM \* Correction Factor ( Table 18 )

Table 22 Steam Correction Factor									
Pressure PSIG	2	5	10	15	20	30	40	50	60
Correction Factor	0.95	1	1.07	1.14	1.19	1.28	1.35	1.42	1.48

Table 23 Hot Water Correction factor				
Entering Water Temperature °F	160	180	200	220
Correction Factor	0.75	1	1.25	1.5

Table 24 Chilled Water Correction Factor				
Entering Water Temperature °F	42	44	45	46
Correction Factor	1.09	1.04	1	0.97

## Filters

### 1- Washable Aluminum

High capacity , low resistance , permanent metal filters , which can be Cleaned in hot water with detergent . They can be used for air cleanliness Required 65-70% arrestance or as an economical alternate to disposable Type pre – filter of high efficiency filter .

EU Class	2
Arrestance (%)	65 - 80

### 2- Panel Filter (Disposable)

Heavy duty disposable panel filters giving primary protection to the Conditioned space or protect more expensive secondary filters . They are available in synthetic fiber pleated media consist of continuous Filament glass fiber of progressive density .

EU Class	3	4	5
Arrestance (%)	80 - 90	90 – 95	-
Dust Spot Efficiency (%)	20 - 25	25 - 40	40 - 60

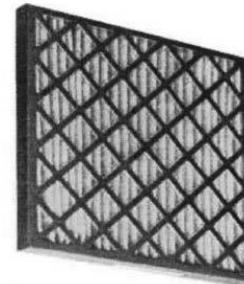

Panel Filter

### 3- Bag Filter

When high performance air filtration long service life and high dust Holding capacity required in air handling unit , then extended surface Pock et filters are selected . filters are available in various efficiency depth , And number of pockets . Dust holding capacity is maximized because dirt is Evenly loaded through out the entire depth of the filter .

EU Class	6	7	8	9
Dust Spot Efficiency (%)	60 - 80	80 - 90	90 - 95	95 - 99

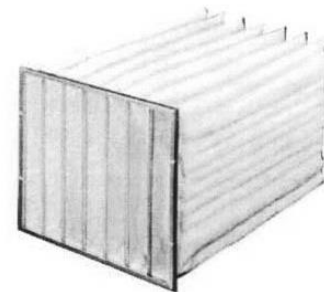

Bag Filter

### 4- Hepa Filters

Hepa filter are used to remove airborne biological contaminants in hospital Critical area . pharmaceutical processing industries as well as to meet exact Requirements of the laboratories and precision manufacturing and micro Electronic industries . Filters are available in 99.97 or 99.99 % efficiency with plywood or galvanized steel casing . Hepa filters are installed on specially designed knife edge type seal framing system with pressure tight lock to prevent air by pass .



Hepa Filter

EU Class	11	12	13	14
Dust Spot Efficiency (%)	99.9 – 99.97	99.97 – 99.99	99.99 – 99.999	99.999 – 99.9995

## (Air Washer Features)

Azar Nasim air washers are designed & manufactured in three basic classes .

### **Class 4 :**

A compact & economical single spray bank air washer specially designed for effective humidifying & air washing purposes .

### **Class 6 :**

A single spray bank unit for medium capacity applications , an ideal air washer for most types evaporative cooling & air washing tasks .

### **Class 8 :**

A highly efficient heavy duty unit with two spray banks used when ever . The utmost in heat transfer . Humidification or air cleaning is required .

Casings and water basins are made of galvanized steel sheets . Basins are 300 mm deep for classes 4 & 6 , 400 mm deep for class 8.

Moisture eliminators installed side by side in close proximity of each other preventing the water droplets from entering the fan section . They also present a large surface area against which water droplets & dust particles first impinge before ending up in the basin .

Centrifugal spray nozzles , contain no cores , vanes of obstructions of any kind and all inside surface are smooth . Nozzles have removable caps which can be taken off for cleaning purposes .

Brass flooding nozzles are installed on separate headers extending across the air washer . They deliver a solid flat stream of water on to the eliminator surface in order to wash off the dust particles & deposits .

An access door with glass inspection window is available on all models .

Make – up water connection & an automatic float valve which controls the water level in the basin are provided .

Quick fill connection to which the fresh water supply may be connected is furnished for rapid filling of the basin .

## Evaporative Cooling Efficiency (E) / Class 4

Table A					
Air Velocity	450	475	500	525	550
E	0.594	0.572	0.555	0.536	0.519

## Evaporative Cooling Efficiency (E) / Class 6 & 8

Table B											
P.F	0.50	0.55	0.60	0.65	0.70	0.75	0.80	0.85	0.90	0.95	1.0
E	0.60	0.64	0.68	0.72	0.76	0.80	0.84	0.88	0.92	0.95	1.0

## Air Washer Performance Factors (P.F)

Table C-1												
Model	250		350		500		700		1000		1200	
	C 6	C 8	C 6	C 8	C 6	C 8	C 6	C 8	C 6	C 8	C 6	C 8
P.F	0.525	0.815	0.525	0.815	0.548	0.821	0.548	0.821	0.548	0.821	0.548	0.821

Table C-2												
Model	1500		1700		2000		2200		2500		3000	
	C 6	C 8	C 6	C 8	C 6	C 8	C 6	C 8	C 6	C 8	C 6	C 8
P.F	0.571	0.854	0.571	0.854	0.571	0.854	0.571	0.854	0.548	0.821	0.571	0.854

Table C-3						
Model	3500		4000		4500	
	C 6	C 8	C 6	C 8	C 6	C 8
P.F	0.571	0.854	0.571	0.854	0.571	0.854

## (Air Washer Selection Procedure)

### Given Data:

- Entering air DB temperature = 95 °F
- Entering air WB temperature = 63 °F
- Sensible cooling load = 85 MBH
- Design air flow rate = 10000 CFM
- Room DB temperature = 77 °F

Determine the required air washer model ,  $Q = 1.085 \times \text{CFM} \times (\text{DB Room} - \text{DB Lvg.})$

$$\text{DB Lvg.} = \text{DB Room} - \frac{Q}{1.085 \times \text{CFM}} = 77 - \frac{85000}{1.085 \times 10000} = 69.16 \text{ °F}$$

Considering the required air flow rate in CFM & the unit available nominal air flow rate , air handling unit model AHU – 1000 is chosen .

Evaporative cooling efficiency (E) is determined as ,

$$E = \frac{\text{DB Ent} - \text{DB Lvg.}}{\text{DB Ent} - \text{WB Ent}} = \frac{95 - 69.16}{95 - 63} = 0.8$$

The coil face area for model 1000 is 20ft<sup>2</sup> there fore .

$$F.V = \frac{10000}{20} = 500 \text{ FPM}$$

Considering the air velocity & the values in table (A) the (E) value for Class 4 air washer is equal to 0.555 which is less than the calculated value there fore Class 4 air washer dose not satisfy the requirement . In this case since the (E) value is know , the (P.F) value from table (B) is determined as being equal to 0.75

Now , considering the unit model AHU – 1000 , the (P.F) value & table (C) the (P.F) value for Class 6 air washer is less than the value calculated there fore , Class 8 washer satisfies the requirement .

We also notice that the (P.F) value given is 0.821 there fore , the actual (E) value is 0.856 (Table B) the Lvg. Air DB temperature is given as .

$$DB \text{ Lvg} = DB \text{ Ent} - E \times (DB \text{ Ent} - WB \text{ Ent}) = 95 - 0.821 \times (95 - 63) = 68.7 \text{ }^\circ\text{F}$$

There fore , the actual air washer cooling capacity is given as.

$$Q = 1.085 \times CFM \times (DB \text{ Room} - DB \text{ Lvg}) = 1.085 \times 10000 \times (77 - 68.7) = 90055 \text{ BTU/hr} \sim 90 \text{ MBH}$$

Entering the psycho metric chart with the leaving air DB & WB temperatures of 68.7 °F & 63 °F respectively , the relative humidity of the air is determined to be 73% .

Note :

Abbreviations Ent & Lvg are air Entering & Leaving air washer .

## Air Washer Class 4

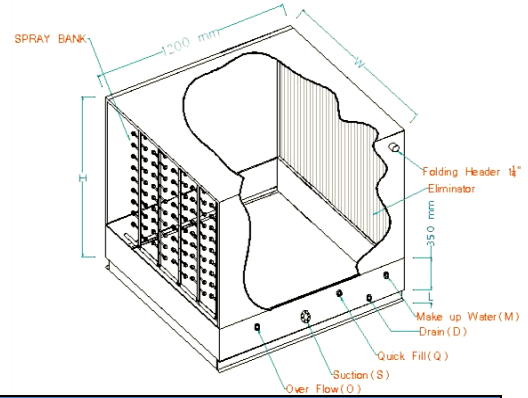

Table 25		Technical Data													
Model	Nominal Air Flow Rate (CFM)	Face Area ft <sup>2</sup>	Water Flow Rate (GPM)	Noz zle Hea d	Pump Head	Weight (Kg)		Dimensions (mm)		Connections (inch)					
						Net.	Oper.	W	H	D	O	S	H	M	Q
AHU 250	2500	5	20	55	59	250	510	1000	1170	1	1	1 ½	1 ½	¾	¾
AHU 350	3500	7	28	55	60	300	560	1100	1320	1	1	1 ½	1 ½	¾	¾
AHU 500	5000	10	40	55	60	350	730	1500	1470	1	1	1 ½	1 ½	¾	¾
AHU 700	7000	15	56	55	61	400	780	1500	1670	1	1	2	2	¾	¾
AHU 1000	10000	20	80	55	62	500	1025	2000	1750	1	1	2	2	¾	¾
AHU 1200	12500	25	100	55	62	550	1075	2000	1950	1	1	2	2	¾	¾
AHU 1500	15000	30	120	55	63	600	1125	2000	2250	1	1	2 ½	3	¾	¾
AHU 1700	17500	35	140	55	64	650	1250	2250	2250	1	1	2 ½	3	¾	¾
AHU 2000	20000	40	160	55	64	700	1360	2400	2330	1	1	3	3	¾	¾
AHU 2200	22500	45	180	55	64	800	1550	2400	2530	1	1	3	3	¾	¾
AHU 2500	25000	50	200	55	62	1100	2150	3200	2130	2*1	2*1	2*2	2*2	¾	¾
AHU 3000	30000	60	240	55	63	1200	2250	4000	2130	2*1	2*1	2*2 ½	2*3	¾	¾
AHU 3500	35000	70	280	55	64	1300	2500	4200	2230	2*1	2*1	2*3	2*3	¾	¾
AHU 4000	40000	80	320	55	64	1400	2720	4500	2350	2*1	2*1	2*3	2*3	¾	¾
AHU 4500	45000	88	360	55	64	1600	3100	5000	2450	2*1	2*1	2*3	2*3	¾	¾

**Note :**

- Nozzle head and pump head are in feet of water .
- Rounding in dimensions and specifications .



## Air Washer Class ٦

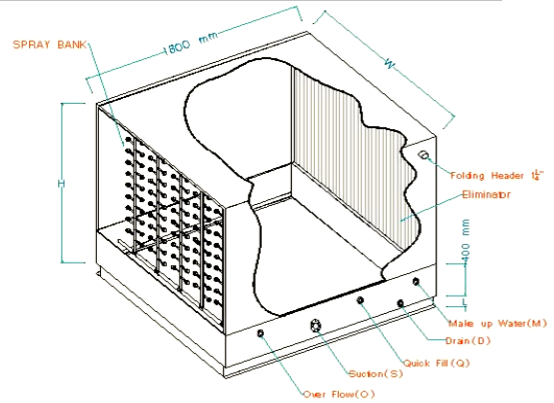

Table 26		Technical Data													
Model	Nominal Air Flow Rate (CFM)	Face Area ft <sup>2</sup>	Water Flow Rate (GPM)	Nozzle Head	Pump Head	Weight (Kg)		Dimensions (mm)		Connections (inch)					
						Net.	Oper.	W	H	D	O	S	H	M	Q
AHU 250	2500	5	30	55	59	450	950	1000	1220	1	1	2	1 ½	¾	¾
AHU 350	3500	7	42	55	60	500	1000	1100	1370	1	1	2	1 ½	¾	¾
AHU 500	5000	10	60	55	60	550	1280	1500	1520	1	1	2	1 ½	¾	¾
AHU 700	7000	15	84	55	61	600	1330	1500	1720	1	1	2	2	¾	1
AHU 1000	10000	20	120	55	62	720	1700	2000	1800	1	1	2 ½	2	1	1
AHU 1200	12500	25	150	55	62	825	1800	2000	2000	1 ½	1 ½	3	2	1	1
AHU 1500	15000	30	180	55	63	900	1900	2000	2300	1 ½	1 ½	3	3	1	1
AHU 1700	17500	35	210	55	64	980	2100	2250	2300	1 ½	1 ½	3	3	1	1
AHU 2000	20000	40	240	55	64	1050	2300	2400	2380	1 ½	1 ½	2*2 ½	3	1	1
AHU 2200	22500	45	270	55	64	1200	2600	2400	2580	1 ½	1 ½	2*2 ½	3	1	1
AHU 2500	25000	50	300	55	62	1650	3600	3200	2180	2*1 ½	2*1 ½	2*3	2*3	1	1
AHU 3000	30000	60	360	55	63	1800	3800	4000	2180	2*1 ½	2*1 ½	2*3	2*3	1	1
AHU 3500	35000	70	420	55	64	1960	4200	4200	2280	2*1 ½	2*1 ½	2*3	2*3	1	1
AHU 4000	40000	80	480	55	64	2100	4600	4500	2400	2*1 ½	2*1 ½	2*3	2*3	1	1
AHU 4500	45000	88	540	55	64	2400	5200	5000	2500	2*1 ½	2*1 ½	2*3	2*3	1	1

## Note :

- Nozzle head and pump head are in feet of water .
- Roughing in dimensions and specifications .

## Air Washer Class ^

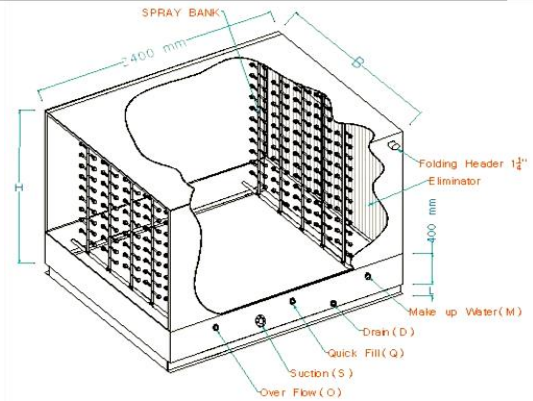

Table 27 Technical Data															
Model	Nominal Air Flow Rate (CFM)	Face Area ft <sup>2</sup>	GPM	Nozzle Head	Pump Head	Weight (Kg)		Dimensions (mm)		Connections (inch)					
						Net.	Oper.	W	H	D	O	S	H	M	Q
AHU 250	2500	5	40	55	59	600	1500	1000	1220	2	2	2	2 ½	¾	¾
AHU 350	3500	7	56	55	60	650	1550	1100	1370	2	2	2	2 ½	¾	¾
AHU 500	5000	10	80	55	60	720	2050	1500	1520	2	2	2 ½	2 ½	¾	1
AHU 700	7000	15	112	55	61	840	2150	1500	1720	2	2	2 ½	2*2	¾	1
AHU 1000	10000	20	160	55	62	950	2750	2000	1800	2	2	3	2*2	1	1
AHU 1200	12500	25	200	55	62	1050	2850	2000	2000	2	2	3	2*3	1	1
AHU 1500	15000	30	240	55	63	1200	3000	2000	2300	2	2	4	2*3	1	1
AHU 1700	17500	35	280	55	64	1375	3400	2250	2300	2	2	4	2*3	1	1
AHU 2000	20000	40	320	55	64	1450	3750	2400	2380	2	2	4	2*3	1	1
AHU 2200	22500	45	360	55	64	1650	4300	2400	2580	2	2	4	2*3	1	1
AHU 2500	25000	50	400	55	62	2100	5700	3200	2180	2*2	2*2	2*3	4*3	1	1
AHU 3000	30000	60	480	55	63	2400	6000	4000	2180	2*2	2*2	2*4	4*3	1	1
AHU 3500	35000	70	560	55	64	2750	6800	4200	2280	2*2	2*2	2*4	4*3	1	1
AHU 4000	40000	80	640	55	64	2900	7500	4500	2400	2*2	2*2	2*4	4*3	1	1
AHU 4500	45000	88	720	55	64	3300	8600	5000	2500	2*2	2*2	2*4	4*3	1	1

**Note :**

- Nozzle head and pump head are in feet of water .
- Roughing in dimensions and specifications .

## Humidifiers

### Spray Nozzle Humidifier

### Spray Nozzle Humidifier

Table 28

Model	Nominal Air Flow Rate (CFM)	Absorbed Moisture		Header Size	Model	Nominal CFM	Absorbed Moisture	KW
		$\Delta W=5$	$\Delta W=10$					
AHU 250	2500	8	15	1	AHU 250	2500	12	4
AHU 350	3500	12	22	1	AHU 350	3500	18	6
AHU 500	5000	16	31	1	AHU 500	5000	24	8
AHU 700	7000	23	44	1 ¼	AHU 700	7000	33	10
AHU 1000	10000	33	62	1 ¼	AHU 1000	10000	49	16
AHU 1200	12500	42	78	1 ¼	AHU 1250	12500	60	20
AHU 1500	15000	50	94	1 ¼	AHU 1500	15000	71	24
AHU 1700	17500	58	125	2	AHU 1750	17500	83	28
AHU 2000	20000	66	110	2	AHU 2000	20000	95	32
AHU 2200	22500	75	156	2*1 ¼	AHU 2250	22500	106	36
AHU 2500	25000	83	140	2*1 ¼	AHU 2500	25000	120	40
AHU 3000	30000	100	188	2*1 ¼	AHU 3000	30000	142	48
AHU 3500	35000	116	220	2*2	AHU 3500	35000	116	56
AHU 4000	40000	132	250	2*2	AHU 4000	40000	190	64
AHU 4500	45000	150	280	2*2	AHU 4500	45000	212	72

Notes :

- $\Delta W$  : Moisture difference between air after & before humidifier (Grain / Lb (of dry air ) )
- Drain size = 0.5 inch

Table 29

Model	Nominal Air Flow Rate (CFM)	Steam Capacity (Lb/hr)					
		$\Delta W = 10$	$\Delta W = 10$	$\Delta W = 10$	$\Delta W = 10$	$\Delta W = 10$	$\Delta W = 10$
AHU 250	2500	13	32	46	64	97	129
AHU 350	3500	18	45	64	89	135	180
AHU 500	5000	26	64	92	127	193	257
AHU 700	7000	36	89	128	178	271	361
AHU 1000	10000	52	128	183	255	387	515
AHU 1200	12500	65	160	230	318	481	645
AHU 1500	15000	79	192	275	382	581	773
AHU 1700	17500	92	223	320	445	677	900
AHU 2000	20000	105	256	367	510	775	1030
AHU 2200	22500	118	288	412	573	870	1158
AHU 2500	25000	130	320	460	636	962	1290
AHU 3000	30000	158	384	550	764	1162	1546
AHU 3500	35000	184	246	640	890	1354	1800
AHU 4000	40000	210	512	734	1020	1550	2060
AHU 4500	45000	236	576	824	1146	1740	2316

Notes :

- $\Delta W$  : Moisture difference between air after & before humidifier (Grain / Lb (of dry air ) )
- Steam humidifier rating at 5 PSI pressure

## Service Area Requirements

Single Zone Horizontal

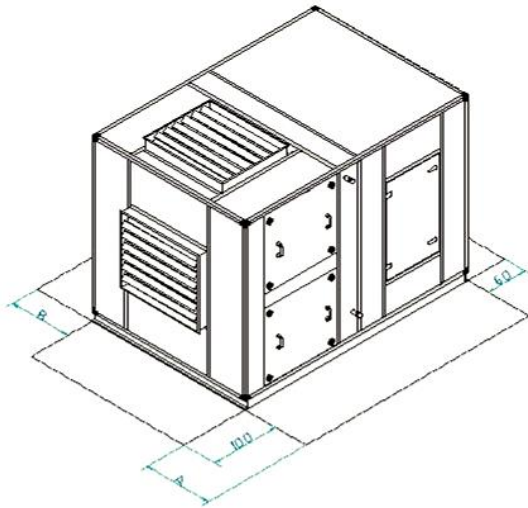

Air Washer

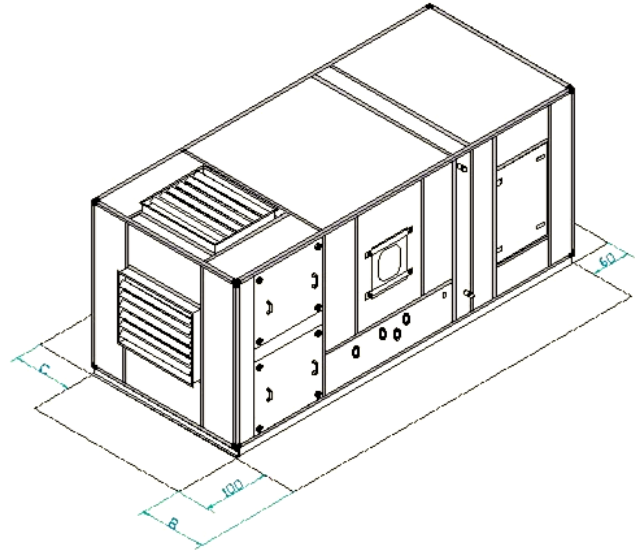

Table 30		Dampers Dimension													
Model	AHU 250	AHU 350	AHU 500	AHU 700	AHU 1000	AHU 1200	AHU 1500	AHU 1700	AHU 2000	AHU 2200	AHU 2500	AHU 3000	AHU 3500	AHU 4000	AHU 4500
A	70	70	80	80	100	100	100	100	120	120	210	210	235	260	275
B	100	100	100	100	100	100	100	100	120	120	210	210	235	260	275
C	110	110	160	160	210	210	210	210	260	275	210	210	235	260	275

Multi-Zone

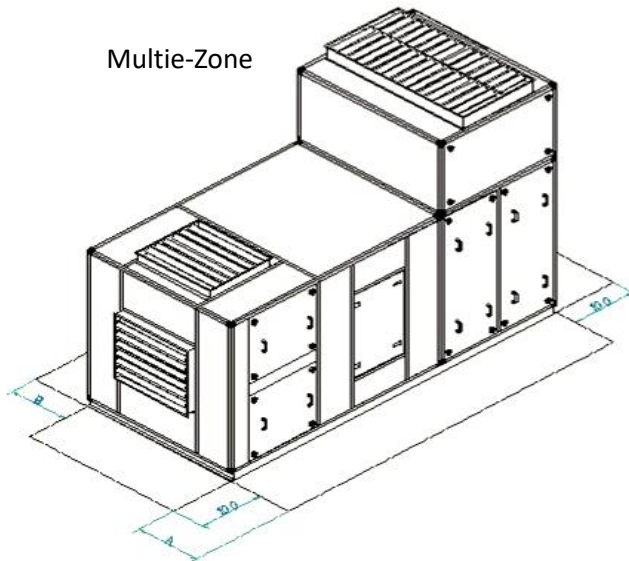

Table 31		Dampers Dimension													
POS Model	AHU 250	AHU 350	AHU 500	AHU 700	AHU 1000	AHU 1200	AHU 1500	AHU 1700	AHU 2000	AHU 2200	AHU 2500	AHU 3000	AHU 3500	AHU 4000	AHU 4500
A	70	70	80	80	100	100	100	100	120	120	210	210	235	260	275
B	110	110	160	160	210	210	210	210	260	275	210	210	235	260	275

Note :

All Dimensions are in mm

## Enthalpy / Altitude

Table 32						
Air Wet Bulb Temp .°F	Altitude (ft.)					
	.	١...	٢...	٣...	٤...	٥...
Enthalpy (BTU / Lb)						
35	13.0	13.2	13.3	13.5	13.7	13.9
36	13.4	13.5	13.8	14.0	14.2	14.5
37	13.9	14.0	14.3	14.4	14.7	14.8
38	14.2	14.5	14.7	15.0	15.1	15.3
39	14.8	15.0	15.2	15.4	15.6	15.9
40	15.2	15.4	15.7	15.9	16.2	16.4
41	15.7	15.9	16.1	16.4	16.6	16.8
42	16.2	16.4	16.6	16.9	17.2	17.4
43	16.6	16.9	17.1	17.4	17.6	18.0
44	17.2	17.4	17.6	17.9	18.2	18.5
45	17.7	17.9	18.2	18.4	18.7	19.0
46	18.2	18.4	18.7	19.0	19.3	19.6
47	18.7	18.9	19.3	19.5	19.8	20.2
48	19.2	19.5	19.8	20.0	20.4	20.8
49	19.7	20.0	20.4	20.6	21.0	21.3
50	20.3	20.6	20.9	21.2	21.6	22.3
51	20.9	21.2	21.5	21.8	22.2	22.6
52	21.4	21.7	22.1	22.5	22.8	23.2
53	22.0	22.4	22.7	23.1	23.5	24.0
54	22.6	23.0	23.4	23.8	24.1	24.6
55	23.2	23.6	24.0	24.4	24.8	25.3
56	23.8	24.2	24.6	25.0	25.5	25.9
57	24.4	24.8	25.3	25.8	26.2	26.7
58	25.2	25.5	25.9	26.4	26.9	27.4
59	25.8	26.2	26.7	27.2	27.6	28.2
60	26.5	26.9	27.4	27.8	28.4	28.9
61	27.2	27.6	28.1	28.6	29.2	29.7
62	27.9	28.3	28.9	29.4	29.9	30.5
63	28.5	29.0	29.6	30.2	30.7	31.4
64	29.3	29.8	30.3	31.0	31.6	32.2
65	30.1	30.6	31.2	31.7	32.3	33.0
66	30.8	31.4	32.0	32.6	33.3	33.9
67	31.6	32.2	32.8	33.5	34.1	34.8
68	32.4	33.0	33.7	34.3	35.0	35.8
69	33.2	33.9	34.5	35.3	35.9	36.7
70	34.0	34.7	35.4	36.1	36.9	37.6
71	34.9	35.6	36.3	37.0	37.9	38.6
72	35.8	36.5	37.3	38.0	38.8	39.7
73	36.7	37.5	38.2	39.0	39.9	40.7
74	37.6	38.4	39.2	40.0	40.9	41.8
75	38.6	39.4	40.2	41.0	42.0	42.9
76	39.6	40.3	41.2	42.1	43.0	44.0
77	40.6	41.4	42.3	43.2	44.2	45.2
78	41.5	42.5	43.4	44.3	45.3	46.4
79	42.6	43.5	44.5	45.5	46.5	47.5
80	43.7	44.6	45.6	46.6	47.6	48.8
81	44.8	45.8	46.7	47.8	48.8	50.0
82	45.9	46.9	48.0	49.0	50.3	51.4
83	47.0	48.1	49.2	50.3	51.5	52.8
84	48.2	49.3	50.4	51.6	52.9	54.2
85	49.4	50.3	51.7	53.0	54.2	55.6

# CONTACT US!

---

- Central Office : 021-48402
- Customer Voice : (ext6)
- Central Office Fax : (ext116)
- Factory Phone : 086-45250025
- Factory Fax : 086-45250022
- Email : [info@azarnasim.com](mailto:info@azarnasim.com)
- Address : No,304,The 3th Floor,  
Toupaz Complex, Next to Yaran Park, After Abazar Cross  
roads, Ayatollah Kashani Blvd,The Second Sq.Of Sadeghieh  
Tehran, IRAN.